

# MSOP 蓋印規範

## Marking Specification for MSOP

PC1-02-033

---

Rev. A

April, 2008

文件變更歷程表 Revision History

Rev. 版本	Initiated 制訂者	Approval Date 核准日期	Description 制定 / 修改內容		Page 頁碼	Reviewed 審核者
			Changed Reason 變更原因	Change Summarized 變更內容摘要		
<b>A</b>	<b>Gerry Weng</b>	<b>2008/4/29</b>	<b>To fulfill ISO requirements</b>	<b>New initiation</b>	<b>All</b>	<b>Peter Yeh</b>

審核 Signatures Required For Approval

Title / Name 職位 / 名稱	Approved 審核通過	Rejected (with Reason) 審核退回之原因	Date 日期
Production Manager Peter Yeh	V		2008/4/28
QA Director PS Yen	V		2008/4/28
Operation Div. VP Simon Leu	V		2008/4/29

分發單位 Distribution

<input checked="" type="checkbox"/> President	<input checked="" type="checkbox"/> Sales	<input checked="" type="checkbox"/> Marketing	<input checked="" type="checkbox"/> R&D
<input type="checkbox"/> G&A / Finance	<input checked="" type="checkbox"/> Operation	<input checked="" type="checkbox"/> QA	<input type="checkbox"/>
<input type="checkbox"/>	<input type="checkbox"/>	<input type="checkbox"/>	<input type="checkbox"/>

## 1 目的 Purpose :

- 1.1 To provide subcontractor instructions for the marking of PhaseLink product TYPES.
- 1.2 In order to ensure consistent presentation of the PhaseLink image, products will adhere to this specification with the exception of specific customer requirements
- 1.3 The following aspects are covered in this specification: marking content, marking location, letter type, abbreviations, customized marking, visual appearance, repair and resistance to

## 2 範圍與職責 Scope and Responsibility :

### 2.1 Scope 範圍 :

- 2.1.1 This specification is applicable to all marked integrated circuits for the MSOP package.
- 2.1.2 This specification is applicable to all PhaseLink and/or subcontracted assembly and test centers which do product marking of PhaseLink products.

### 2.2 Responsibility 職責 :

- 2.2.1 Production department: Responsible for definition of marking rules, creation and maintenance of marking specifications and distribution to all subcontractors °

## 3 Applicable Document 應用文件 :

NA

## 4 Definition 名詞定義 :

- 4.1 Order Number: Product Number used for customer ordering.
- 4.2 Mark Number: Product Number used for marking.

## 5 流程圖 Flowchart

NA

## 6 Work Instruction 作業說明：

### 6.1 General marking format:

Front side marking: PLAAA – BB - XXX C D G – EE

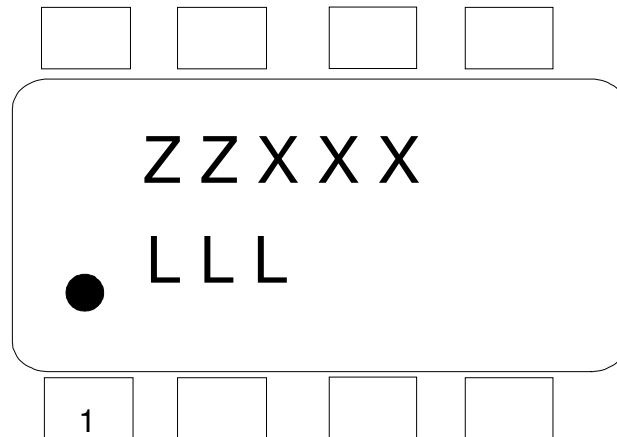

#### 6.1.1 Line 1:

6.1.1.1 ZZ : Marking Number (2 digits, the detail please refer to appendix 7.1)

6.1.1.2 XXX : ID code (4 digits, the detail please refer to appendix 7.1 and 7.4)

#### 6.1.2 Line 2:

6.1.2.1 LLL : The last three digits of Production Lot No. (the detail please refer to appendix 7.3)

6.1.3 ● : Pin 1 identification dot (the dimension of pin 1 dot is 10 +/- 2 mils, and the color is white color, the distance between dot and package body edge is 10 ± 5 mils)

6.2 Special marking for the product of PL611-248/ PL611-252:

Front side marking: PLAAA – BB - XXX C D G - EE



6.2.1 Line 1:

6.2.1.1 ZZ : Marking Number (2 digits, the detail please refer to appendix 7.1)

6.2.1.2 XXX : ID code (3 digits, the detail please refer to appendix 7.1 and 7.2)

6.2.2 Line 2:

6.2.2.1 EE : Revision of part number (2 digits, e.g. A0 ~ Z9)

6.2.2.2 YWW : Date code (3 digits; Y means year e.g. 8 means year 2008, WW means week code, e.g. 01 means WK01...)

6.2.3 ● : Pin 1 identification dot (the dimension of pin 1 dot is 10 +/- 2 mils, and the color is while color, the distance between dot and package body edge is 10 ± 5 mils)

## 6.3 Non-programmable product marking:

Front side marking: PLAAA – BB(B) C D - EE

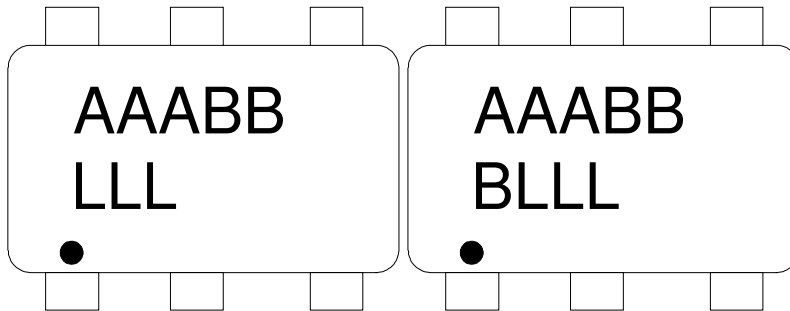

### 6.3.1 Line 1:

6.3.1.1 AAABB or AAABB(B): Part number (5 or 6 digits)

### 6.3.2 Line 2:

6.3.2.1 LLL : The last three digits of Production Lot No. (3 digits, the detail please refer to appendix 7.3)

6.3.3 ● : Pin 1 identification dot (the dimension of pin 1 dot is 10 +/- 2 mils, and the color is while color, the distance between dot and package body edge is 10 ± 5 mils)

## 7 Appendix 附錄：

### 7.1 Part number & marking list:

Product Family	Part Number	Marking (ZZXXX)
C611	PL611-01-XXX	C1XXX
	PL611-20-XXX	C2XXX
	PL611-30-XXX	C3XXX
	PL611-31-XXX	C4XXX
	PL611-31-248	C4001
	PL611-31-252	C4002
	PL611-05-XXX	C5XXX
	PL611-12-XXX	C6XXX
	PL611-07-XXX	C7XXX

### 7.2 ID Code:

Code	Purpose
001~Z99	programming code

### 7.3 Production lot number:

7.3.1 Total five digits.

7.3.2 1<sup>st</sup> digit: Foundry code

7.3.3 2<sup>nd</sup> digit: Subcontractor code.

7.3.4 3<sup>rd</sup> to 5<sup>th</sup> digits: series number such as 001 ~ Z99

### 7.4 Wafer Foundry code:

Code	Subcontractor
A	Chartered
B	UMC

7.5 Assembly Subcontractor code:

<b>Code</b>	<b>Subcontractor</b>
A	CET
O	TICP
Q	Sigurd
S	TMC
T	Greatek
U	Unisem
W	YTEC