

PL565-08 Tuning Assistant for 600~800MHz

Doc ID: PAN1105051

By: Eddy van Keulen

Date: 5-May-11

The PL565-08 AFM VCXO can be assembled in the KD-VB0F48 ceramic substrate. For optimum performance, the substrate needs to be assembled with certain values inductors depending upon the output frequency.

Figure 1: KD-VB0F48 substrate layout

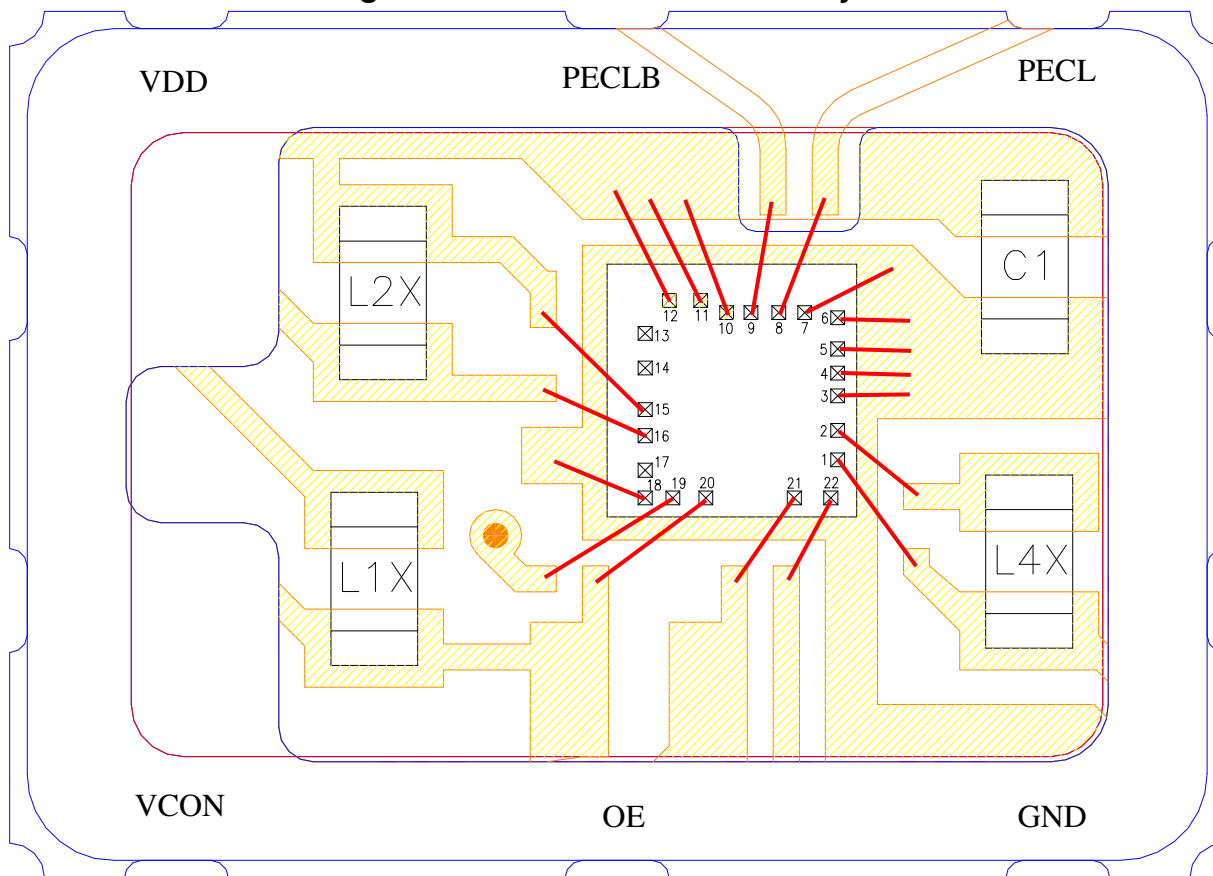

- This tuning assistant is optimized for using the PL565-08DC in the range 600 ~ 800MHz.
- Inductor L1X sets the VCXO frequency pulling range.
- Inductor L2X is the first stage filter for the AFM at crystal frequency $\times 2$.
- Inductor L4X is the second stage filter for the AFM at crystal frequency $\times 4$.
- Capacitor C1 is for power supply decoupling. The advised value is $0.01\mu\text{F}$ or 10nF .

The following page shows tables of recommended inductor values based upon crystal parameters and output frequency.

PL565-08 Tuning Assistant for 600~800MHz

Inductor L1X: Coilcraft 0402HP* series or 0402AF* series

| Output Frequency | Crystal Frequency | Crystal C1 Value | L1X Value | Estimated Frequency Pulling |
|------------------|-------------------|------------------|-----------------|-----------------------------|
| 600 MHz | 150 MHz | 5.0 fF | 220 nH | -140 / +140 ppm |
| | | 7.0 fF | 150 nH | -140 / +140 ppm |
| 625 MHz | 156 MHz | 4.0 fF | 220 nH | -120 / +125 ppm |
| | | 5.0 fF | 150 nH | -110 / +115 ppm |
| | | | 220 nH | -155 / +150 ppm |
| 650 MHz | 163 MHz | 7.0 fF | 150 nH | -150 / +145 ppm |
| | | 4.0 fF | 220 nH | -130 / +135 ppm |
| 5.0 fF | 150 nH | | -115 / +120 ppm | |
| | 220 nH | | -170 / +165 ppm | |
| 700 MHz | 175 MHz | 7.0 fF | 100 nH | -120 / +125 ppm |
| | | 4.0 fF | 150 nH | -160 / +155 ppm |
| 5.0 fF | 180 nH | | -125 / +130 ppm | |
| | 150 nH | | -130 / +135 ppm | |
| 700 MHz | 175 MHz | 7.0 fF | 100 nH | -130 / +130 ppm |

* Note: 0402HP has a ceramic core and 0402AF has a ferrite core. The behavior with the two types can be notably different! 0402AF has a lower Q-factor and the crystal oscillation amplitude will be lower. Slightly better phase noise has been observed with 0402AF but its higher ESR also lowers the negative resistance margin, specifically at the highest frequencies.

Inductor L2X: Coilcraft 0402CS series or 0402HP series

| Output Frequency Range | L2X Value |
|------------------------|-----------|
| 600MHz ~ 627MHz | 18 nH |
| 627MHz ~ 650MHz | 16 nH |
| 650MHz ~ 678MHz | 15 nH |
| 678MHz ~ 709MHz | 13 nH |
| 709MHz ~ 747MHz | 12 nH |
| 747MHz ~ 756MHz | 11 nH |
| 756MHz ~ 774MHz | 10 nH |
| 774MHz ~ 788MHz | 9.5 nH |
| 788MHz ~ 800MHz | 9.0 nH |

Inductor L4X: Coilcraft 0402CS series or 0402HP series

| Output Frequency Range | L4X Value |
|------------------------|-----------|
| 600MHz ~ 629MHz | 6.2 nH |
| 629MHz ~ 645MHz | 5.6 nH |
| 645MHz ~ 665MHz | 5.1 nH |
| 665MHz ~ 682MHz | 4.7 nH |
| 682MHz ~ 703MHz | 4.3 nH |
| 703MHz ~ 720MHz | 3.9 nH |
| 720MHz ~ 737MHz | 3.6 nH |
| 737MHz ~ 777MHz | 3.3 nH |
| 777MHz ~ 800MHz | 2.7 nH |