

PL560-08 Tuning Assistant for 250~600MHz

Doc ID: PAN1201051

By: Eddy van Keulen

Date: 5-Jan-12

The PL560-08 AFM VCXO can be assembled in the KD-VB0F48 ceramic substrate. For optimum performance, the substrate needs to be assembled with certain values inductors depending upon the output frequency.

Figure 1: KD-VB0F48 substrate layout

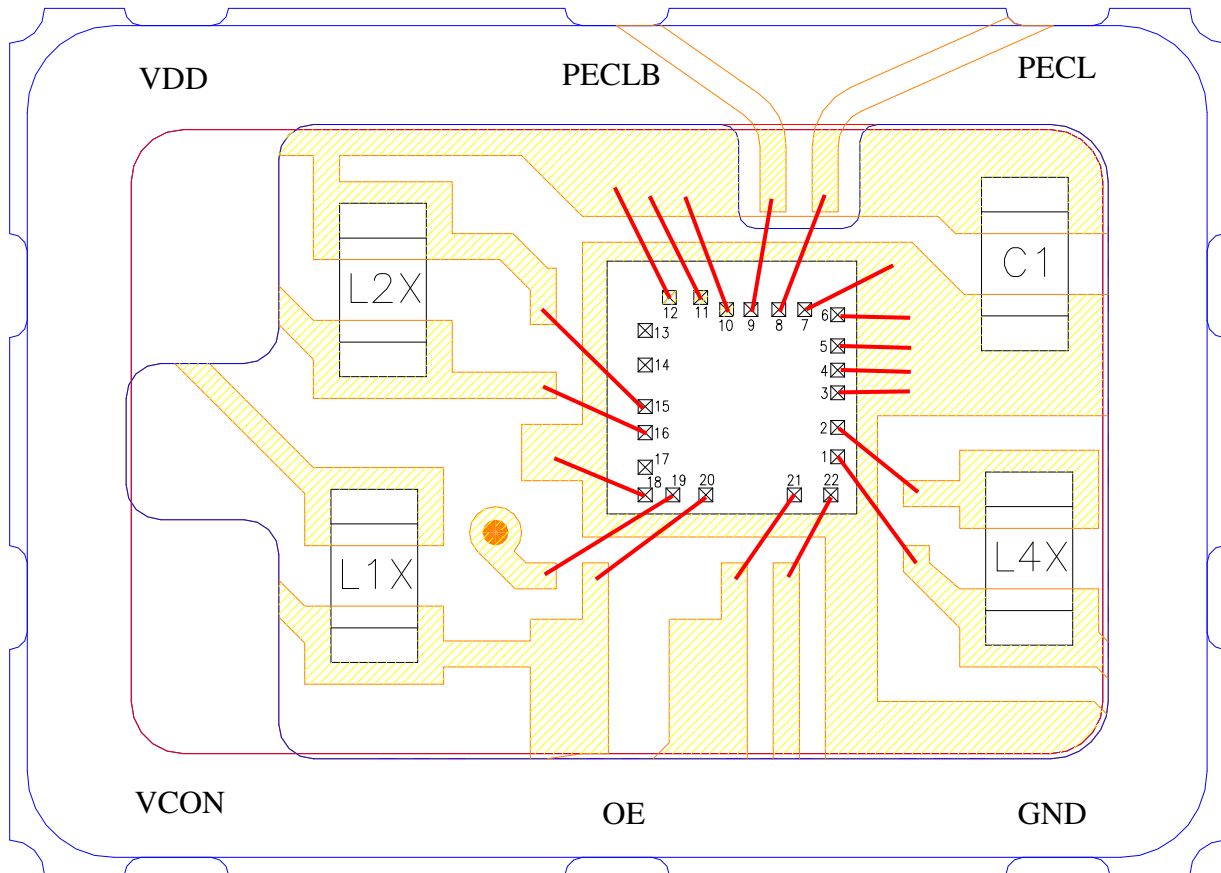

- This tuning assistant is optimized for using the PL560-08DC in the range 250 ~ 600MHz.
- Inductor L1X sets the VCXO frequency pulling range.
- Inductor L2X is the first stage filter for the AFM at crystal frequency $\times 2$.
- Inductor L4X is the second stage filter for the AFM at crystal frequency $\times 4$.
- Capacitor C1 is for power supply decoupling. The advised value is $0.01\mu\text{F}$ or 10nF .

The following pages show tables of recommended inductor values based upon crystal parameters and output frequency.

PL560-08 Tuning Assistant for 250~600MHz

Inductor L1X: Coilcraft 0402HP* series or 0402AF* series

Output Frequency	Crystal Frequency	Crystal C1 Value	L1X Value	Estimated Frequency Pulling
300 MHz	75 MHz	4.0 fF	560 nH	-130 / +105 ppm
		5.0 fF	470 nH	-145 / +110 ppm
			560 nH	-155 / +115 ppm
		7.0 fF	470 nH	-180 / +130 ppm
400 MHz	100 MHz	4.0 fF	470 nH	-145 / +115 ppm
		5.0 fF	390 nH	-160 / +120 ppm
			470 nH	-175 / +130 ppm
		7.0 fF	270 nH	-170 / +120 ppm
			330 nH	-185 / +135 ppm
500 MHz	125 MHz	4.0 fF	390 nH	-150 / +120 ppm
		5.0 fF	270 nH	-150 / +115 ppm
			330 nH	-170 / +130 ppm
		7.0 fF	220 nH	-175 / +125 ppm

* Note: 0402HP has a ceramic core and 0402AF has a ferrite core. The behavior with the two types can be notably different! 0402AF has a lower Q-factor and the crystal oscillation amplitude will be lower. Slightly better phase noise has been observed with 0402AF but its higher ESR also lowers the negative resistance margin, specifically at the highest frequencies.

PL560-08 Tuning Assistant for 250~600MHz

Inductor L2X: Coilcraft 0402HP series

Output Frequency Range	L2X Value
250MHz ~ 271MHz	100 nH
271MHz ~ 298MHz	82 nH
298MHz ~ 326MHz	68 nH
326MHz ~ 349MHz	56 nH
349MHz ~ 363MHz	51 nH
363MHz ~ 377MHz	47 nH
377MHz ~ 392MHz	43 nH
392MHz ~ 400MHz	40 nH
400MHz ~ 407MHz	39 nH
407MHz ~ 415MHz	37 nH
415MHz ~ 426MHz	36 nH
426MHz ~ 444MHz	33 nH
444MHz ~ 465MHz	30 nH
465MHz ~ 479MHz	27 nH
479MHz ~ 486MHz	26 nH
486MHz ~ 495MHz	25 nH
495MHz ~ 504MHz	24 nH
504MHz ~ 514MHz	23 nH
514MHz ~ 524MHz	22 nH
524MHz ~ 535MHz	21 nH
535MHz ~ 546MHz	20 nH
546MHz ~ 559MHz	19 nH
559MHz ~ 581MHz	18 nH
581MHz ~ 600MHz	16 nH

Inductor L4X: Coilcraft 0402HP series

Output Frequency Range	L4X Value
250MHz ~ 260MHz	47 nH
260MHz ~ 270MHz	43 nH
270MHz ~ 276MHz	40 nH
276MHz ~ 281MHz	39 nH
281MHz ~ 286MHz	37 nH
286MHz ~ 294MHz	36 nH
294MHz ~ 307MHz	33 nH
307MHz ~ 322MHz	30 nH
322MHz ~ 332MHz	27 nH
332MHz ~ 337MHz	26 nH
337MHz ~ 343MHz	25 nH
343MHz ~ 350MHz	24 nH
350MHz ~ 357MHz	23 nH
357MHz ~ 364MHz	22 nH
364MHz ~ 372MHz	21 nH
372MHz ~ 380MHz	20 nH
380MHz ~ 389MHz	19 nH
389MHz ~ 405MHz	18 nH
405MHz ~ 421MHz	16 nH
421MHz ~ 441MHz	15 nH
441MHz ~ 462MHz	13 nH
462MHz ~ 477MHz	12 nH
477MHz ~ 495MHz	11 nH
495MHz ~ 508MHz	10 nH
508MHz ~ 518MHz	9.5 nH
518MHz ~ 527MHz	9.0 nH
527MHz ~ 536MHz	8.7 nH
536MHz ~ 553MHz	8.2 nH
553MHz ~ 573MHz	7.5 nH
573MHz ~ 593MHz	6.8 nH
593MHz ~ 600MHz	6.2 nH

Note: The Coilcraft 0402HP series is relatively new and the series contains more values than the older 0402CS series. The 0402HP series allows for more accurate tuning of the tank circuits.

PL560-08 Tuning Assistant for 250~600MHz

Inductor L2X: Coilcraft 0402CS series

Output Frequency Range	L2X Value
250MHz ~ 271MHz	100 nH
271MHz ~ 298MHz	82 nH
298MHz ~ 326MHz	68 nH
326MHz ~ 349MHz	56 nH
349MHz ~ 363MHz	51 nH
363MHz ~ 377MHz	47 nH
377MHz ~ 394MHz	43 nH
394MHz ~ 410MHz	39 nH
410MHz ~ 426MHz	36 nH
426MHz ~ 444MHz	33 nH
444MHz ~ 465MHz	30 nH
465MHz ~ 489MHz	27 nH
489MHz ~ 505MHz	24 nH
505MHz ~ 514MHz	23 nH
514MHz ~ 530MHz	22 nH
530MHz ~ 547MHz	20 nH
547MHz ~ 559MHz	19 nH
559MHz ~ 581MHz	18 nH
581MHz ~ 600MHz	16 nH

Inductor L4X: Coilcraft 0402CS series

Output Frequency Range	L4X Value
250MHz ~ 260MHz	47 nH
260MHz ~ 272MHz	43 nH
272MHz ~ 283MHz	39 nH
283MHz ~ 294MHz	36 nH
294MHz ~ 307MHz	33 nH
307MHz ~ 322MHz	30 nH
322MHz ~ 339MHz	27 nH
339MHz ~ 351MHz	24 nH
351MHz ~ 357MHz	23 nH
357MHz ~ 369MHz	22 nH
369MHz ~ 381MHz	20 nH
381MHz ~ 389MHz	19 nH
389MHz ~ 405MHz	18 nH
405MHz ~ 421MHz	16 nH
421MHz ~ 441MHz	15 nH
441MHz ~ 462MHz	13 nH
462MHz ~ 477MHz	12 nH
477MHz ~ 495MHz	11 nH
495MHz ~ 508MHz	10 nH
508MHz ~ 518MHz	9.5 nH
518MHz ~ 527MHz	9.0 nH
527MHz ~ 536MHz	8.7 nH
536MHz ~ 553MHz	8.2 nH
553MHz ~ 573MHz	7.5 nH
573MHz ~ 593MHz	6.8 nH
593MHz ~ 600MHz	6.2 nH