

Low Skew Output Buffer

FEATURES

- Frequency Range:
 - 15 to 170MHz @ 3.3V
 - 15 to 145MHz @ 2.5V
- Internal Phase Locked Loop Allows Spread Spectrum Modulation on Reference Clock to Pass to Outputs.
- Zero Input to Output Delay
- Less Than 700ps Device to Device Skew
- Less Than 200ps Skew Between Outputs
- Less Than 100ps Cycle to Cycle Jitter
- 2.5V or 3.3V Power Supply
- Available in 8-Pin SOP or 6-pin SOT GREEN/ RoHS Compliant Packages

PIN CONFIGURATION

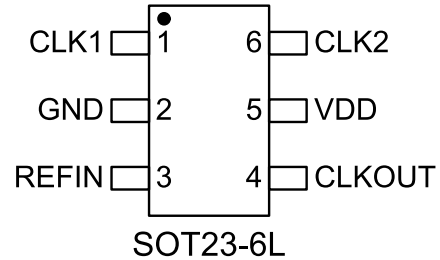
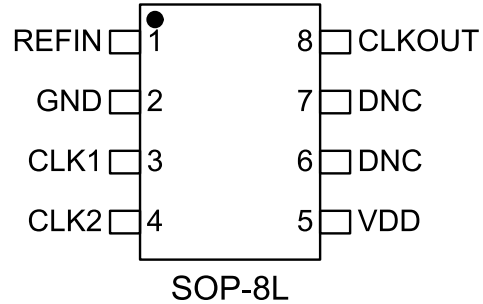

DESCRIPTION

The PL102-10 is a high performance, low skew, low jitter zero delay buffer designed to distribute high speed clocks and is available in 8-pin SOP or 6-pin SOT23 package. It has two outputs that are synchronized with the input. The synchronization is established via CLKOUT feed back to the input of the PLL. Since the skew between the input and output is less than ± 350 ps, the device acts as a zero delay buffer.

BLOCK DIAGRAM

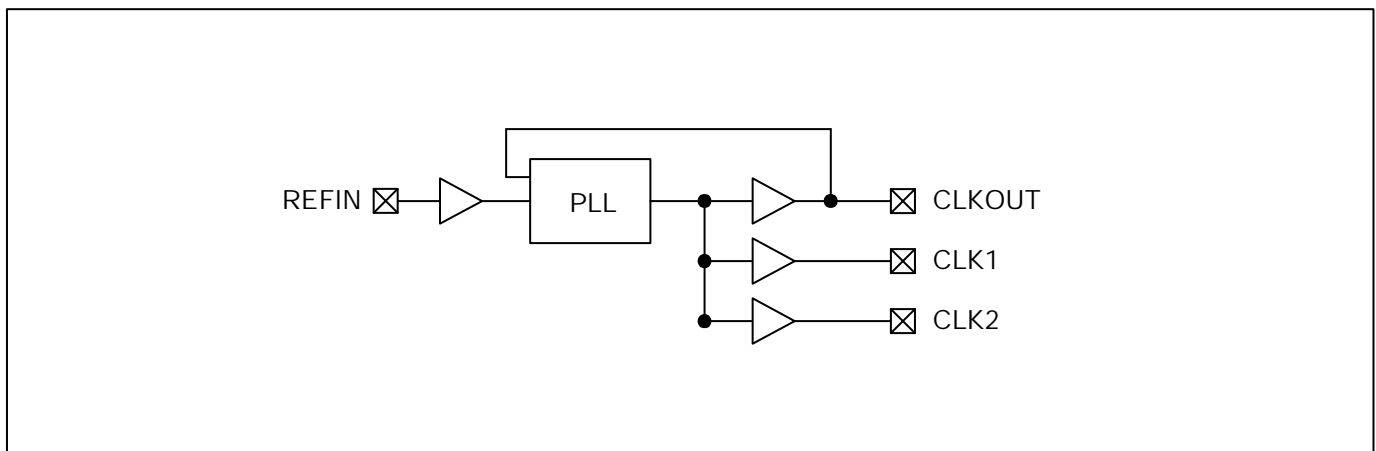

Low Skew Output Buffer

PIN DESCRIPTIONS

Pin Name	Pin Number		Type	Description
	SOP-8L	SOT23-6L		
REFIN	1	3	I	Input reference frequency. Spread spectrum modulation on this signal will be passed to the output (up to 100kHz SST modulation).
GND	2	2	P	Ground Connection.
CLK1	3	1	O	Buffered clock output.
CLK2*	4	6	O	Buffered clock output.
VDD	5	5	P	2.5V or 3.3V Power Supply connection.
DNC	6, 7	-	-	Do Not Connect
CLKOUT	8	4	O	Buffered clock output. Internal feed back on this pin.

*Note: If CLK2 is pulled high during startup the device will enter test mode.

ELECTRICAL SPECIFICATIONS

1. Absolute Maximum Ratings

PARAMETERS	SYMBOL	MIN.	MAX.	UNITS
Supply Voltage	V_{DD}		4.6	V
Input Voltage, dc	V_I	-0.5	$V_{DD}+0.5$	V
Output Voltage, dc	V_O	-0.5	$V_{DD}+0.5$	V
Storage Temperature	T_S	-65	150	°C
Ambient Operating Temperature*	T_A	-40	85	°C
Junction Temperature	T_J		125	°C
Lead Temperature (soldering, 10s)			260	°C

Exposure of the device under conditions beyond the limits specified by Maximum Ratings for extended periods may cause permanent damage to the device and affect product reliability. These conditions represent a stress rating only, and functional operations of the device at these or any other conditions above the operational limits noted in this specification is not implied. *Operating temperature is guaranteed by design. Parts are tested to commercial grade only.

2. Electrical Characteristics

PARAMETERS	SYMBOL	CONDITIONS	MIN.	TYP.	MAX.	UNITS
Supply Voltage	V_{DD}		2.25		3.63	V
Input Low Voltage	V_{IL}				0.8	V
Input High Voltage	V_{IH}		2.0			V
Output Low Voltage	V_{OL}	$I_{OL} = 24mA$			0.4	V
Output High Voltage	V_{OH}	$I_{OH} = 24mA$	2.4			V
Supply Current	I_{DD}	Unloaded outputs at 100MHz, $V_{DD}=3.3V$.		22	30	mA

Low Skew Output Buffer

3. Switching Characteristics

PARAMETERS	SYMBOL	CONDITIONS	MIN.	TYP.	MAX.	UNITS
Input/Output Frequency	t1	2.5V/3.3V	15		145/170	MHz
Duty Cycle	DC	Measured at $V_{DD}/2$, $C_L=15pF$, $F_{out} = 100MHz$	45	50	55	%
Rise Time	T_r	Measured between 10% and 90% V_{DD} , $C_L=15pF$		1.2	1.5	ns
Fall Time	T_f	Measured between 90% and 10%, $C_L=15pF$		1.2	1.5	ns
Output to Output Skew	T_{skew}	All outputs equally loaded, $C_L=15pF$			200	ps
Delay, REF Rising Edge to CLKOUT Rising Edge	T_{delay}	Measured at $V_{DD}/2$		0	± 350	ps
Device to Device Skew	$T_{dsk-dsk}$	Measured at $V_{DD}/2$ on the CLKOUT pins of devices		0	700	ps
Cycle to Cycle Jitter	$T_{cyc-cyc}$	Measured at 100MHz			60	ps
PLL Lock Time	T_{lock}	Stable power supply, valid clock presented on REF pin			1.0	ms
Jitter; Absolute Jitter	T_{jabs}	Measured 10,000 cycles, low jitter input signal		20	50	ps
Jitter; 1-sigma	T_{j1-s}	Measured 10,000 cycles, low jitter input signal		9	15	ps

SWITCHING WAVEFORMS

Duty Cycle Timing

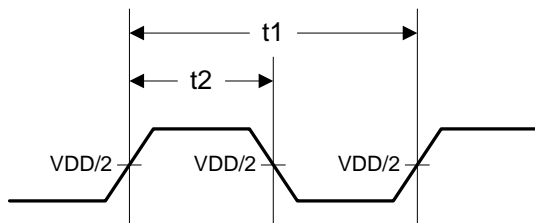

Output - Output Skew

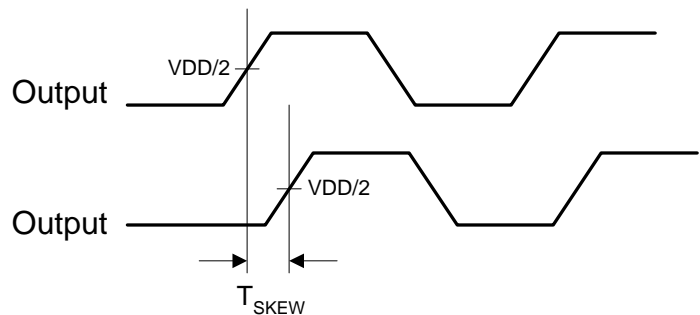

SWITCHING WAVE FORMS

All Outputs Rise/Fall Time

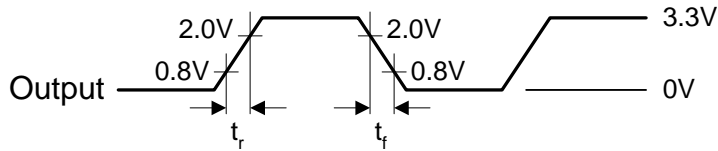

Input to Output Propagation Delay

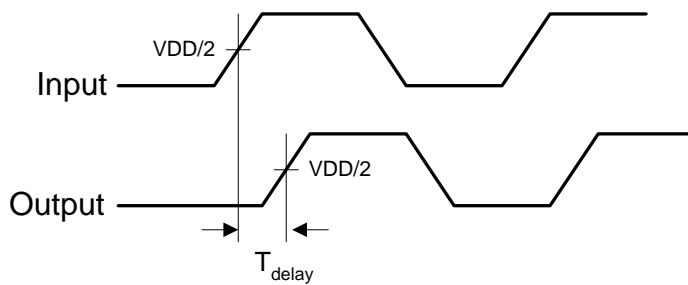

Device to Device Skew

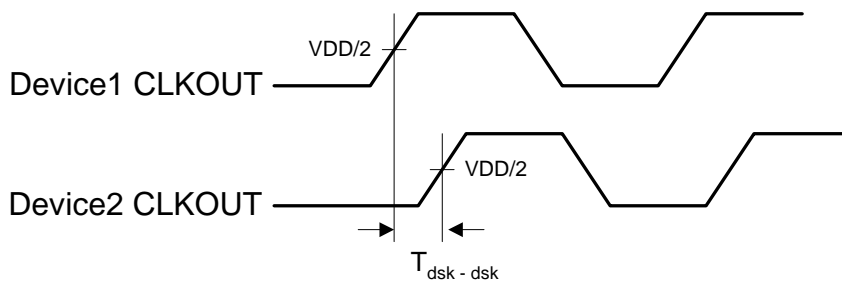

Output-Output Skew

The skew between CLKOUT and the CLK(1-2) outputs is not dynamically adjusted by the PLL. Since CLKOUT is one of the inputs to the PLL, zero phase difference is maintained from REF to CLKOUT. If all outputs are equally loaded, zero phase difference will be maintained from REF to all outputs.

If applications requiring zero output-output skew, all the outputs must be equally loaded.

If the CLK(1-2) outputs are less loaded than CLKOUT, CLK(1-2) outputs will lead it; if the CLK(1-2) is more loaded than CLKOUT, CLK(1-2) will lag the CLKOUT.

Since the CLKOUT and the CLK(1-2) outputs are identical, they all start at the same time, but difference loads cause them to have different rise times and different times crossing the measurement thresholds.

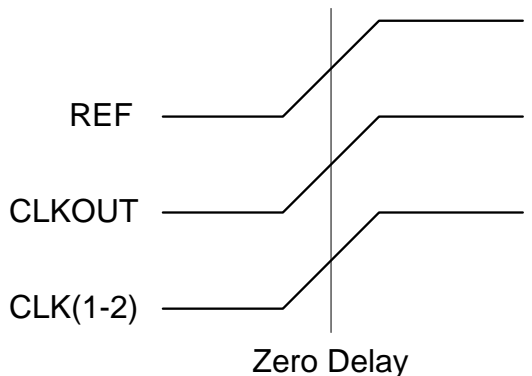

REF input and all outputs are equally loaded

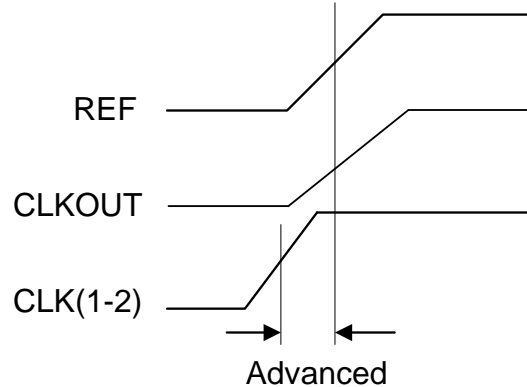

REF input and CLK(1-2) outputs are equally loaded, with CLK(1-2) less loaded than CLKOUT.

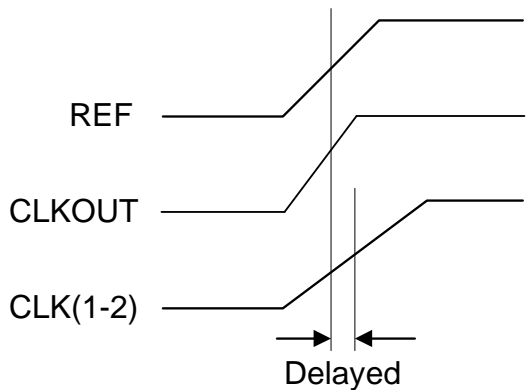

REF input and CLK(1-2) outputs loaded equally, with CLK(1-2) more loaded than CLKOUT.

PACKAGE INFORMATION (GREEN PACKAGE COMPLIANT)

SOP-8L

Symbol	Dimension in MM	
	Min.	Max.
A	1.35	1.75
A1	0.10	0.25
A2	1.25	1.50
B	0.33	0.53
C	0.19	0.27
D	4.80	5.00
E	3.80	4.00
H	5.80	6.20
L	0.40	0.89
e	1.27 BSC	

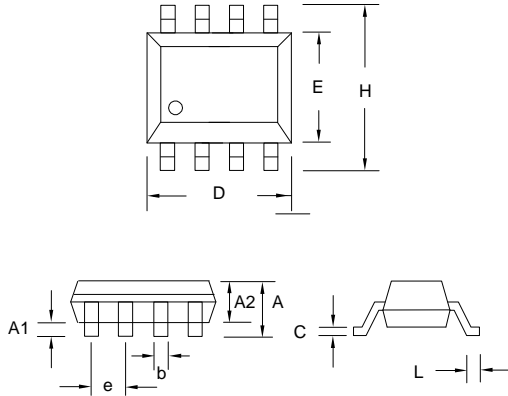

SOT23-6L

Symbol	Dimension in MM	
	Min.	Max.
A	1.05	1.35
A1	0.05	0.15
A2	1.00	1.20
B	0.30	0.50
C	0.08	0.20
D	2.80	3.00
E	1.50	1.70
H	2.60	3.0
L	0.35	0.55
e	0.95 BSC	

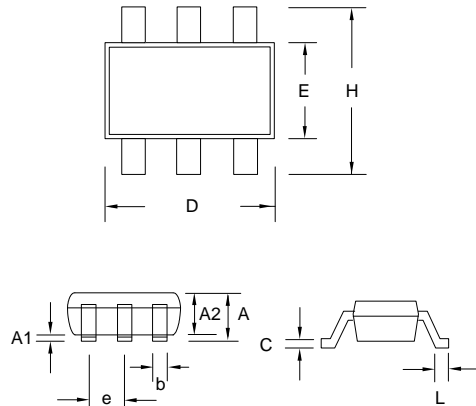

ORDERING INFORMATION (GREEN PACKAGE COMPLIANT)

For part ordering, please contact our Sales Department:
47745 Fremont Blvd., Fremont, CA 94538, USA
Tel: (510) 492-0990 Fax: (510) 492-0991

PART NUMBER

The order number for this device is a combination of the following:
Part number, Package type and Operating temperature range

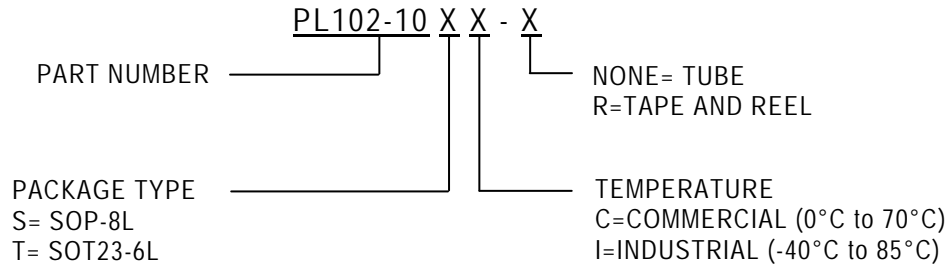

Part / Order Number	Marking*	Package Option
PL102-10SC	P102-10 SC LLL	8-Pin SOP (Tube)
PL102-10SC-R	P102-10 SC LLL	8-Pin SOP (Tape and Reel)
PL102-10TC-R	C10A0 LLL	6-Pin SOT (Tape and Reel)

*Note: LLL designates lot number

PhaseLink Corporation, reserves the right to make changes in its products or specifications, or both at any time without notice. The information furnished by Phaselink is believed to be accurate and reliable. However, PhaseLink makes no guarantee or warranty concerning the accuracy of said information and shall not be responsible for any loss or damage of whatever nature resulting from the use of, or reliance upon this product. LIFE SUPPORT POLICY: PhaseLink's products are not authorized for use as critical components in life support devices or systems without the express written approval of the President of PhaseLink Corporation.

Solder reflow profile available at www.phaselink.com/QA/solderingGreen.pdf