

**DC – 200 MHz 1:2 Fan-Out Buffer**

**FEATURES**

- Supports 3.3V, 2.5V, and 1.8V power supplies
- Frequency Support
  - 3.3V Supplies: DC – 200 MHz
  - 2.5V Supplies: DC – 150 MHz
  - 1.8V Supplies: DC – 100 MHz
- Output Enable (OE) pin
- LVCMOS Input/Output
  - Accepts SST and non SST clock signals
- Operating temperature range from -40°C to 85°C
- Available in space-saving 6-pin DFN GREEN/RoHS compliant package.

The PL123-02N is a low-cost general purpose 1-to-2 LVCMOS fan-out buffer. An output enable (OE) pin is available to enable the outputs or disable them into an active low state. When the outputs are disabled, the IC consumes less than 5µA of power. The OE pin incorporates a pull up resistor giving a default condition of logic “1”.

The input and outputs are LVCMOS levels and operate up to 200 MHz. Input signals with Spread Spectrum Modulation can also be used. The spread spectrum modulation will not be affected by the PL123-02N as the signal passes through the IC. A space-saving 6-pin DFN package enables designs requiring minimal board area.

**DESCRIPTION**

**BLOCK DIAGRAM**

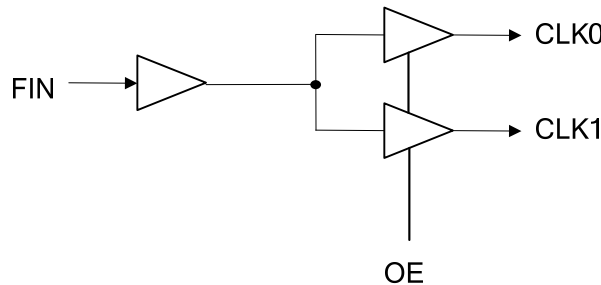

**PIN CONFIGURATION AND DESCRIPTION**

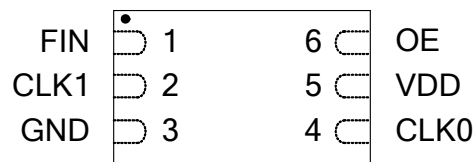

**DFN-6L**  
**(2.0 x 1.3 x 0.6mm)**

| Name | Pin Assignment | Type | Description  |
|------|----------------|------|--|
| FIN  | 1              | I    | Reference input pin  |
| CLK1 | 2              | O    | Clock Output   |
| GND  | 3              | P    | GND connection   |
| CLK0 | 4              | O    | Clock Output   |
| VDD  | 5              | P    | V <sub>DD</sub> connection   |
| OE   | 6              | I    | Output Enable (OE) input. Outputs are enabled when set high. Outputs are 'Active low' mode when set low. |

## DC – 200 MHz 1:2 Fan-Out Buffer

### ELECTRICAL SPECIFICATIONS

#### ABSOLUTE MAXIMUM RATINGS

| PARAMETERS                            | SYMBOL   | MIN. | MAX.         | UNITS |
|---------------------------------------|----------|------|--------------|-------|
| Supply Voltage Range                  | $V_{DD}$ | -0.5 | 4.6          | V     |
| Input Voltage Range                   | $V_I$    | -0.5 | $V_{DD}+0.5$ | V     |
| Output Voltage Range                  | $V_O$    | -0.5 | $V_{DD}+0.5$ | V     |
| Soldering Temperature (Green package) |          |      | 260          | °C    |
| Storage Temperature                   | $T_S$    | -65  | 150          | °C    |
| Ambient Operating Temperature*        |          | -40  | 85           | °C    |

Exposure of the device under conditions beyond the limits specified by Maximum Ratings for extended periods may cause permanent damage to the device and affect product reliability. These conditions represent a stress rating only, and functional operations of the device at these or any other conditions above the operational limits noted in this specification is not implied. \*Operating temperature is guaranteed by design. Parts are tested to commercial grade only.

#### AC SPECIFICATIONS

| PARAMETERS               | CONDITIONS                        | MIN.                | TYP. | MAX.                | UNITS |
|--------------------------|-----------------------------------|---------------------|------|---------------------|-------|
| Frequency <sup>[1]</sup> | @ $V_{DD} = 3.3V$ , 15pF Load     | DC                  |      | 200                 | MHz   |
|                          | @ $V_{DD} = 2.5V$ , 15pF Load     |                     |      | 150                 |       |
|                          | @ $V_{DD} = 1.8V$ , 15pF Load     |                     |      | 100                 |       |
| Input Voltage Low        |                                   |                     |      | $0.3 \times V_{DD}$ | V     |
| Input Voltage High       |                                   | $0.7 \times V_{DD}$ |      |                     | V     |
| Output Enable Time       | $T_a = 25^\circ C$ , 15pF Load    |                     |      | 2                   | ms    |
| Output Rise Time         | 15pF Load, 10/90% $V_{DD}$ , 3.3V |                     | 2.0  | 3.0                 | ns    |
| Output Fall Time         | 15pF Load, 90/10% $V_{DD}$ , 3.3V |                     | 2.0  | 3.0                 | ns    |
| Duty Cycle               | Dependant upon input duty cycle   |                     |      |                     | %     |

Notes: [1] Higher frequencies may be achieved for lower capacitive loads.

**DC – 200 MHz 1:2 Fan-Out Buffer**

**DC SPECIFICATIONS**

| PARAMETERS                                       | SYMBOL    | CONDITIONS                           | MIN.           | TYP. | MAX. | UNITS   |
|--|-----------|--------------------------------------|----------------|------|------|---------|
| Supply Current, Dynamic, with Loaded CMOS Output | $I_{DD}$  | @ $V_{DD} = 3.3V$ , 32kHz, load=15pF |                | 0.8  |      | mA      |
| Supply Current, Dynamic, with Loaded CMOS Output | $I_{DD}$  | @ $V_{DD} = 2.5V$ , 32kHz, load=15pF |                | 0.6  |      | mA      |
| Supply Current, Dynamic, with Loaded CMOS Output | $I_{DD}$  | @ $V_{DD} = 1.8V$ , 32kHz, load=15pF |                | 0.4  |      | mA      |
| Supply Current, Dynamic, with Loaded Outputs     | $I_{DD}$  | When OE=0                            |                |      | 5    | $\mu A$ |
| Operating Voltage                                | $V_{DD}$  |                                      | 1.62           |      | 3.63 | V       |
| Output Low Voltage                               | $V_{OL}$  | $I_{OL} = +4mA$                      |                |      | 0.4  | V       |
| Output High Voltage                              | $V_{OH}$  | $I_{OH} = -4mA$                      | $V_{DD} - 0.4$ |      |      | V       |
| Output Current                                   | $I_{OSD}$ | $V_{OL} = 0.4V$ , $V_{OH} = 2.4V$    | 8              |      |      | mA      |

**PACKAGE DRAWINGS (GREEN PACKAGE COMPLIANT)**

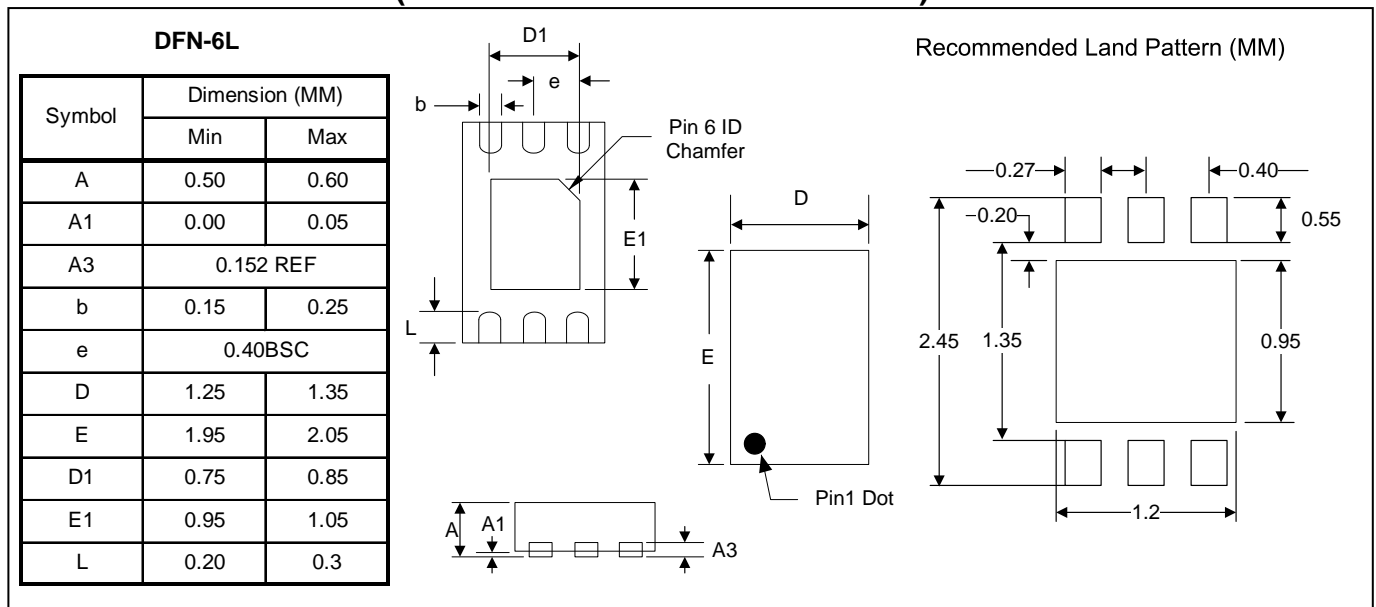

**ORDERING INFORMATION (GREEN PACKAGE COMPLIANT)**

*For part ordering, please contact our Sales Department:*

2880 Zanker Road, San Jose, CA 95134, USA

Tel: (408) 571-1668 Fax: (408) 571-1688

**PART NUMBER**

The order number for this device is a combination of the following:

Part number, Package type and Operating temperature range

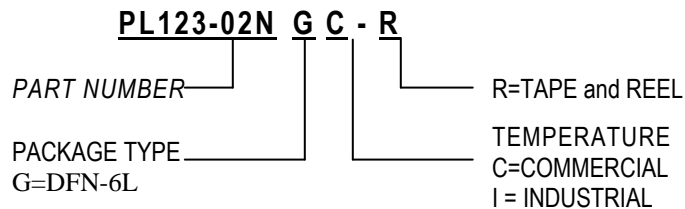

| Part /Order Number | Marking*   | Package Option            |
|--------------------|------------|---------------------------|
| PL123-02NGC-R      | 02N<br>LLL | 6-Pin DFN (Tape and Reel) |
| PL123-02NGI-R      | 02N<br>LLL | 6-Pin DFN (Tape and Reel) |

\*Note: LLL designates lot number

*PhaseLink Corporation, reserves the right to make changes in its products or specifications, or both at any time without notice. The information furnished by Phaselink is believed to be accurate and reliable. However, PhaseLink makes no guarantee or warranty concerning the accuracy of said information and shall not be responsible for any loss or damage of whatever nature resulting from the use of, or reliance upon this product.*

**LIFE SUPPORT POLICY:** PhaseLink's products are not authorized for use as critical components in life support devices or systems without the express written approval of the President of PhaseLink Corporation.

Solder reflow profile available at [www.phaselink.com/QA/solderingGreen.pdf](http://www.phaselink.com/QA/solderingGreen.pdf)