

**Low Skew Zero Delay Buffer**

**FEATURES**

- Frequency Range 10MHz to 134 MHz
- Output Options:
  - 5 outputs *PL123-05*
  - 9 outputs *PL123-09*
- Zero input - output delay
- Optional Drive Strength:
  - Standard (8mA) *PL123-05/-09*
  - High (12mA) *PL123-05H/-09H*
- 3.3V,  $\pm 10\%$  operation
- Available in Commercial and Industrial temperature ranges
- Available in 16-Pin SOP or TSSOP (*PL123-09*), and 8-Pin SOP (*PL123-05*) packages

**DESCRIPTION**

The PL123-05/-09 (-05H/-09H for High Drive) are high performance, low skew, low jitter zero delay buffers designed to distribute high speed clocks. They have one (*PL123-05*) or two (*PL123-09*) low-skew output banks, of 4 outputs each, that are synchronized with the input. The *PL123-09* allows control of the banks of outputs by using the S1 and S2 inputs as shown in the Selector Definition table on page 2.

The synchronization is established via CLKOUT feed back to the input of the PLL. Since the skew between the input and output is less than  $\pm 100\text{ps}$ , the device acts as a zero delay buffer. The input output propagation delay can be advanced or delayed by adjusting the load on the CLKOUT pin.

These parts are not intended for 5V input-tolerant applications.

**BLOCK DIAGRAM**

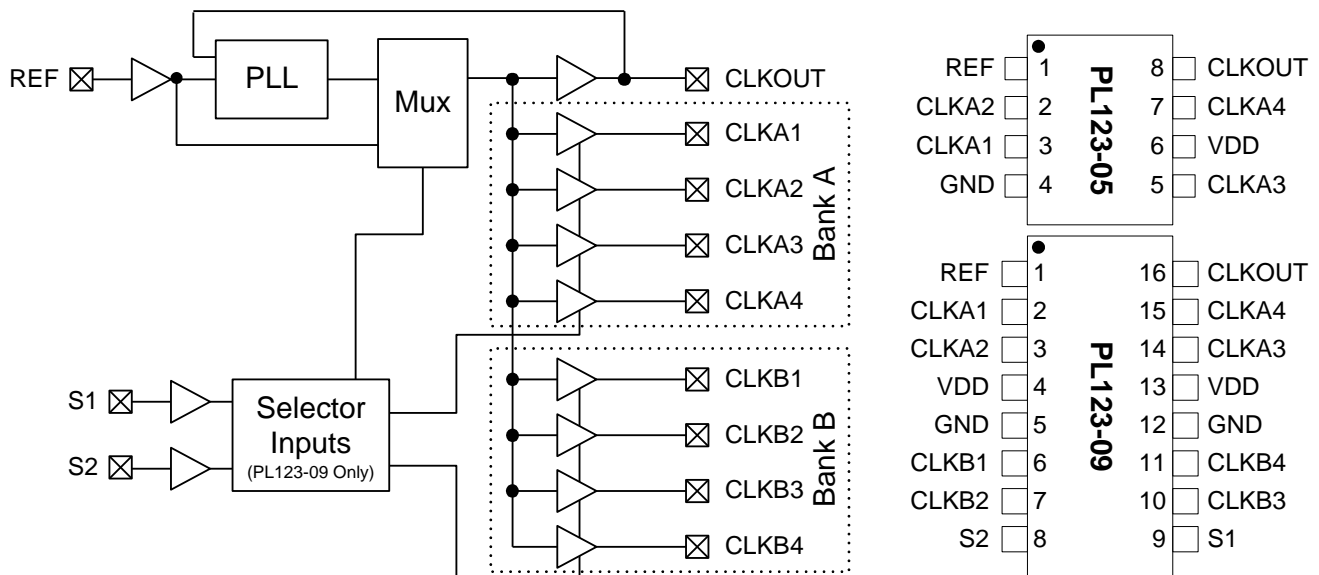

## Low Skew Zero Delay Buffer

### PIN DESCRIPTIONS

Name	PL123-09		PL123-05	Type	Description
	TSSOP-16L	SOP-16L	SOP-8L		
REF <sup>[1]</sup>	1	1	1	I	Input reference frequency.
CLKA1 <sup>[2]</sup>	2	2	3	O	Buffered clock output, Bank A
CLKA2 <sup>[2]</sup>	3	3	2	O	Buffered clock output, Bank A
VDD	4,13	4,13	6	P	VDD connection
GND	5,12	5,12	4	P	GND connection
CLKB1 <sup>[2]</sup>	6	6	-	O	Buffered clock output, Bank B
CLKB2 <sup>[2]</sup>	7	7	-	O	Buffered clock output, Bank B
S2 <sup>[3]</sup>	8	8	-	I	Selector input
S1 <sup>[3]</sup>	9	9	-	I	Selector input
CLKB3 <sup>[2]</sup>	10	10	-	O	Buffered clock output, Bank B
CLKB4 <sup>[2]</sup>	11	11	-	O	Buffered clock output, Bank B
CLKA3 <sup>[2]</sup>	14	14	5	O	Buffered clock output, Bank A
CLKA4 <sup>[2]</sup>	15	15	7	O	Buffered clock output, Bank A
CLKOUT <sup>[2]</sup>	16	16	8	O	Buffered clock output. Internal feedback on this pin.

**Notes:** 1: Weak pull-down. 2: Weak pull-down on all outputs. 3: Weak Pull-Up on S1 and S2

### SELECTOR DEFINITION FOR PL123-09

S2	S1	CLOCK A1–A4 (Bank A)	CLOCK B1–B4 (Bank B)	CLKOUT	Output Source	PLL Shutdown
0	0	Three-state	Three-state	Driven	PLL	N
0	1	Driven	Three-state	Driven	PLL	N
1	0	Driven	Driven	Driven	Reference	Y
1	1	Driven	Driven	Driven	PLL	N

### INPUT / OUTPUT SKEW CONTROL

The PL123-05/-09 will achieve Zero Delay from input to output when all the outputs are loaded equally. Adjustments to the input/output delay can be made by adding additional loading to the CLKOUT pin. Please contact PhaseLink for more information.

**Low Skew Zero Delay Buffer**

**LAYOUT RECOMMENDATIONS**

The following guidelines are to assist you with a performance optimized PCB design:

**Signal Integrity and Termination Considerations**

- Keep traces short!
- Trace = Inductor. With a capacitive load this equals ringing!
- Long trace = Transmission Line. Without proper termination this will cause reflections ( looks like ringing ).
- Design long traces as “striplines” or “microstrips” with defined impedance.
- Match trace at one side to avoid reflections bouncing back and forth.

**Decoupling and Power Supply Considerations**

- Place decoupling capacitors as close as possible to the VDD pin(s) to limit noise from the power supply
- Addition of a ferrite bead in series with VDD can help prevent noise from other board sources
- Value of decoupling capacitor is frequency dependant. Typical values to use are 0.1 $\mu$ F for designs using frequencies < 50MHz and 0.01 $\mu$ F for designs using frequencies > 50MHz.

**Typical CMOS termination**

Place Series Resistor as close as possible to CMOS output

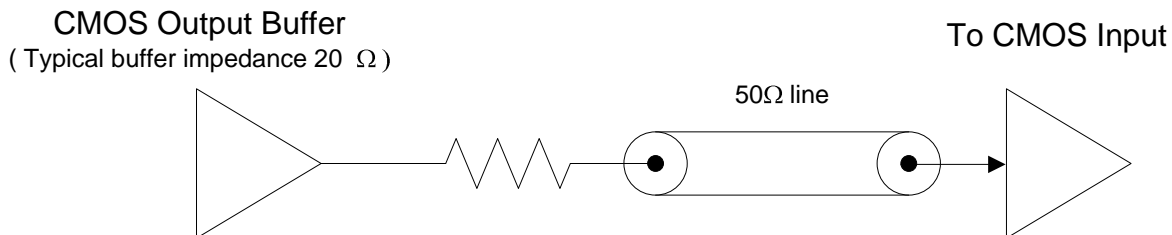

Connect a 33  $\Omega$  series resistor at each of the output clocks to enhance the stability of the output signal

**Low Skew Zero Delay Buffer**

**ABSOLUTE MAXIMUM CONDITIONS**

Supply Voltage to Ground Potential ..... -0.5V to 4.6V  
 DC Input Voltage .....  $V_{SS} - 0.5V$  to 4.6V  
 Storage Temperature ..... -65°C to 150°C

Junction Temperature..... 150°C  
 Static Discharge Voltage  
 (per MIL-STD-883, Method 3015)..... > 2000V

**OPERATING CONDITIONS**

Parameter	Description	Min.	Max.	Unit
$V_{DD}$	Supply Voltage	3.0	3.6	V
$T_A$	Commercial Operating Temperature (ambient temperature)	0	70	°C
	Industrial Operating Temperature (ambient temperature)	-40	85	°C
$C_L$	Load Capacitance, below 100 MHz	—	30	pF
	Load Capacitance, above 100 MHz	—	10	pF
$C_{IN}$	Input Capacitance	—	7	pF
$t_{PU}$	Power-up time for all $V_{DD}$ s to reach minimum specified voltage (power ramps must be monotonic)	0.05	250	ms

**ELECTRICAL CHARACTERISTICS**

Parameter	Description	Test Conditions	Min.	Max.	Unit
$V_{IL}$	Input LOW Voltage		—	0.8	V
$V_{IH}$	Input HIGH Voltage		2.5	—	V
$I_{IL}$	Input LOW Current	$V_{IN} = 0V$	—	50	μA
$I_{IH}$	Input HIGH Current	$V_{IN} = V_{DD}$	—	100	μA
$V_{OL}$	Output LOW Voltage <sup>[4]</sup>	$I_{OL} = 8\text{ mA}$ $I_{OL} = 12\text{ mA}$	—	0.4	V
$V_{OH}$	Output HIGH Voltage <sup>[4]</sup>	$I_{OH} = -8\text{ mA}$ $I_{OH} = -12\text{ mA}$	2.4	—	V
$I_{DD}$	Supply Current (Unloaded Outputs)	66.67MHz with unloaded outputs Commercial Temp.	—	32	mA
		66.67MHz with unloaded outputs Industrial Temp.	—	45	mA

**Notes:** 4. Parameter is guaranteed by design and characterization. Not 100% tested in production.

**Low Skew Zero Delay Buffer**
**SWITCHING CHARACTERISTICS <sup>[5]</sup>**

Parameter	Name	Test Conditions	Min.	Typ.	Max.	Unit
t <sub>1</sub>	Output Frequency	30-pF load	10	–	100	MHz
		10-pF load	10	–	134	MHz
	Duty Cycle <sup>[4]</sup> = t <sub>2</sub> ÷ t <sub>1</sub>	Measured at 1.4V, F <sub>OUT</sub> = 66.67MHz	40	50	60	%
	Duty Cycle <sup>[4]</sup> = t <sub>2</sub> ÷ t <sub>1</sub>	Measured at 1.4V, F <sub>OUT</sub> <50MHz	45	50	55	%
t <sub>3</sub>	Rise Time <sup>[4]</sup>	Measured between 0.8V and 2.0V	–	2.5	–	ns
	Rise Time <sup>[4]</sup> (High Drive)	Measured between 0.8V and 2.0V	–	1.5	–	ns
t <sub>4</sub>	Fall Time <sup>[4]</sup>	Measured between 0.8V and 2.0V	–	2.5	–	ns
	Fall Time <sup>[4]</sup> (High Drive)	Measured between 0.8V and 2.0V	–	1.5	–	ns
t <sub>5</sub>	Output to Output Skew	All outputs equally loaded	–	–	250	ps
t <sub>6A</sub>	Delay, REF Rising Edge to CLKOUT Rising Edge <sup>[4]</sup>	Measured at VDD/2	–	0	±350	ps
t <sub>6B</sub>	Delay, REF Rising Edge to CLKOUT Rising Edge <sup>[4]</sup>	Measured at VDD/2. Measured in PLL bypass mode, <b>PL123-09 only</b> .	1	5	8.5	ns
t <sub>7</sub>	Device to Device Skew <sup>[4]</sup>	Measured at VDD/2 on the CLKOUT pin	–	0	700	ps
t <sub>8</sub>	Output Slew Rate <sup>[4]</sup>	Measured between 0.8V and 2.0V using Test Circuit #2	1	–	–	V/ns
t <sub>J</sub>	Cycle to Cycle Jitter <sup>[4]</sup>	Measured at 66.67 MHz, loaded outputs	–	75	200	ps
t <sub>LOCK</sub>	PLL Lock Time <sup>[4]</sup>	Stable power supply, valid clock presented on REF pin	–	–	1	ms

**Notes:**

4. Parameter is guaranteed by design and characterization. Not 100% tested in production.  
 5. All parameters are specified with loaded outputs.

**Low Skew Zero Delay Buffer**

**SWITCHING WAVEFORMS**

**Duty Cycle Timing**

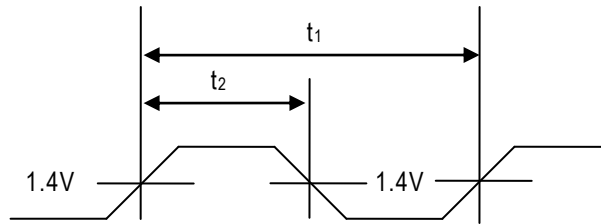

**All Outputs Rise/Fall Time**

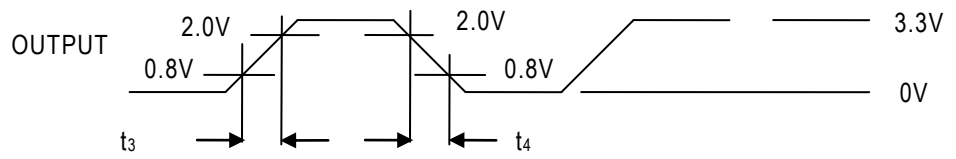

**Output-Output Skew**

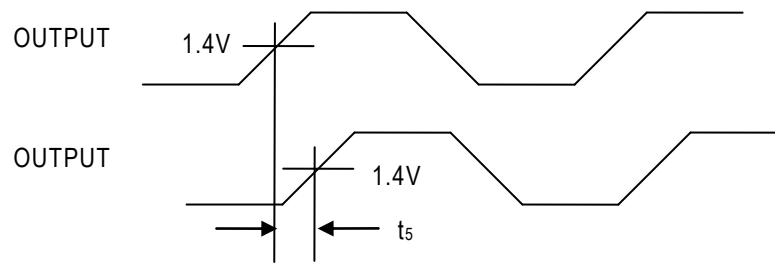

**Input-Output Propagation Delay**

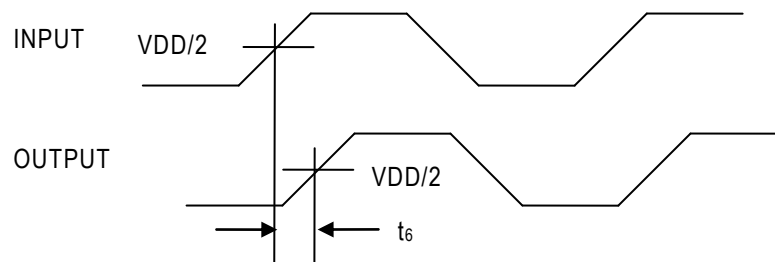

**Device-Device Skew**

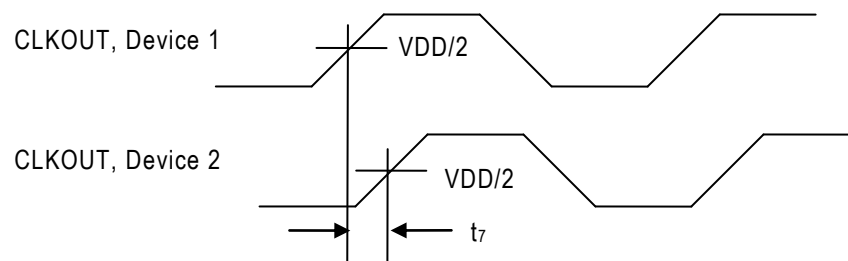

**Low Skew Zero Delay Buffer**

**TEST CIRCUITS**

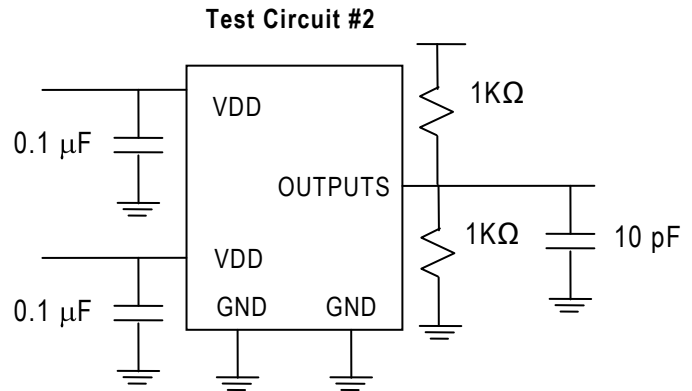
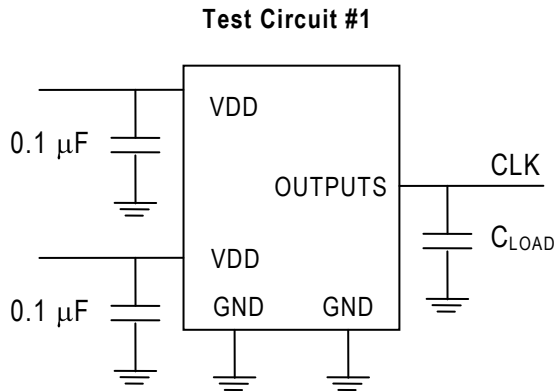

**Low Skew Zero Delay Buffer**

**PACKAGE DRAWINGS (GREEN PACKAGE COMPLIANT)**

**SOP-16L and TSSOP-16L ( mm )**

Symbol	SOP		TSSOP	
	Min.	Max.	Min.	Max.
A	1.35	1.75	-	1.20
A1	0.10	0.25	0.05	0.15
B	0.33	0.51	0.19	0.30
C	0.19	0.25	0.09	0.20
D	9.80	10.00	4.90	5.10
E	3.80	4.00	4.30	4.50
H	5.80	6.20	6.40 BSC	
L	0.40	1.27	0.45	0.75
e	1.27 BSC		0.65 BSC	

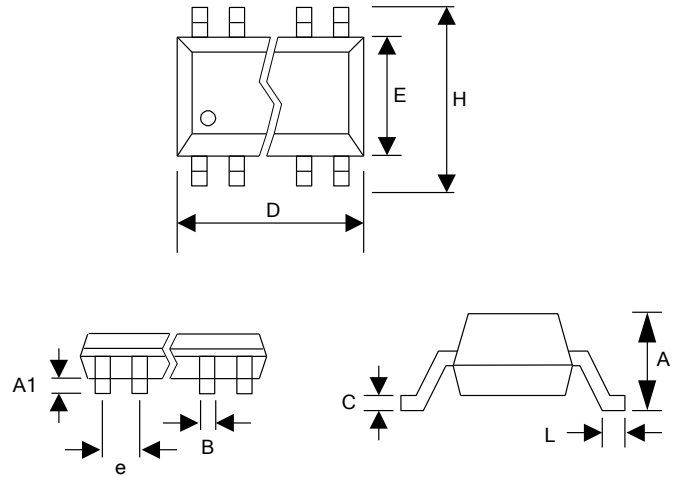

**SOP 8L**

Symbol	Dimension in MM	
	Min.	Max.
A	1.35	1.75
A1	0.10	0.25
A2	1.25	1.50
B	0.33	0.53
C	0.19	0.27
D	4.80	5.00
E	3.80	4.00
H	5.80	6.20
L	0.40	0.89
e	1.27 BSC	

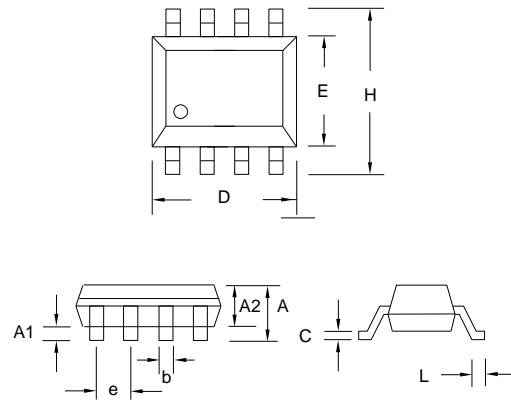

**Low Skew Zero Delay Buffer**

**ORDERING INFORMATION**

**For part ordering, please contact our Sales Department:**

2880 Zanker Road, Suite 103 San Jose, CA 95134  
Tel (408) 571-1668 Fax (408) 571-1688

**PART NUMBER**

The order number for this device is a combination of the following:  
Part number, Package type and Operating temperature range

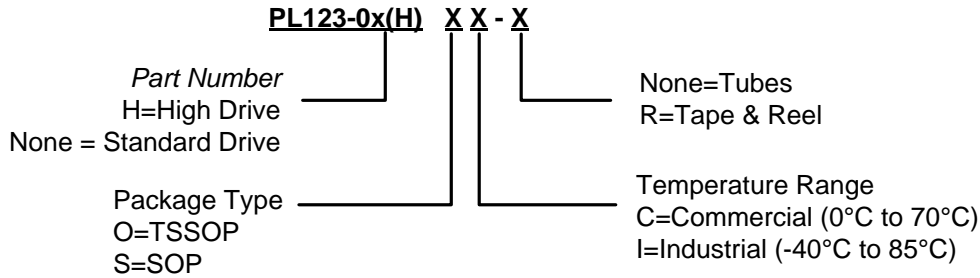

Part/Order Number (Commercial)	Marking* (Commercial)	Part/Order Number (Industrial)	Marking* (Industrial)	Package Option
PL123-05SC	P12305 SC	PL123-05SI	P12305 SI	8-Pin SOP Tube
PL123-05SC-R	LLLLL	PL123-05SI-R	LLLLL	8-Pin SOP (Tape and Reel)
PL123-05HSC	P12305H SC	PL123-05HSI	P12305H SI	8-Pin SOP Tube
PL123-05HSC-R	LLLLL	PL123-05HSI-R	LLLLL	8-Pin SOP (Tape and Reel)
PL123-09OC	P12309 OC	PL123-09OI	P12309 OI	16-Pin TSSOP Tube
PL123-09OC-R	LLLLL	PL123-09OI-R	LLLLL	16-Pin TSSOP (Tape and Reel)
PL123-09HOC	P12309H OC	PL123-09HOI	P12309H OI	16-Pin TSSOP Tube
PL123-09HOC-R	LLLLL	PL123-09HOI-R	LLLLL	16-Pin TSSOP (Tape and Reel)
PL123-09SC	P12309 SC	PL123-09SI	P12309 SI	16-Pin SOP Tube
PL123-09SC-R	LLLLL	PL123-09SI-R	LLLLL	16-Pin SOP (Tape and Reel)
PL123-09HSC	P12309H SC	PL123-09HSI	P12309H SI	16-Pin SOP Tube
PL123-09HSC-R	LLLLL	PL123-09HSI-R	LLLLL	16-Pin SOP (Tape and Reel)

\*Note: LLLLL designates lot number

PhaseLink Corporation, reserves the right to make changes in its products or specifications, or both at any time without notice. The information furnished by PhaseLink is believed to be accurate and reliable. However, PhaseLink makes no guarantee or warranty concerning the accuracy of said information and shall not be responsible for any loss or damage of whatever nature resulting from the use of, or reliance upon this product.

**LIFE SUPPORT POLICY:** PhaseLink's products are not authorized for use as critical components in life support devices or systems without the express written approval of the President of PhaseLink Corporation.