

FEATURES

- LVCMOS output
- Selectable Drive capability
 - Drive 15pF or 30pF output load
- Single AC coupled input (min. 100mV swing).
- Accepts LVCMOS or Sine Wave inputs.
- Input range from 0 to 200 MHz.
- OE High (PLL130-07) or OE Low (PL130-07A) Enable
- 2.5V to 3.3V operation.
- Available in 8-Pin SOP, 8-Pin TSSOP and 3x3mm 16-Pin QFN.

DESCRIPTION

The PLL130-07 is a low cost, high performance, high speed, buffer that reproduces any input frequency from 0 to 200MHz. It provides an LVCMOS output with 15pF output load drive capability. Any input signal with at least 100mV swing can be used as reference signal. This chip is ideal for conversion from sine wave to LVCMOS.

PIN CONFIGURATION

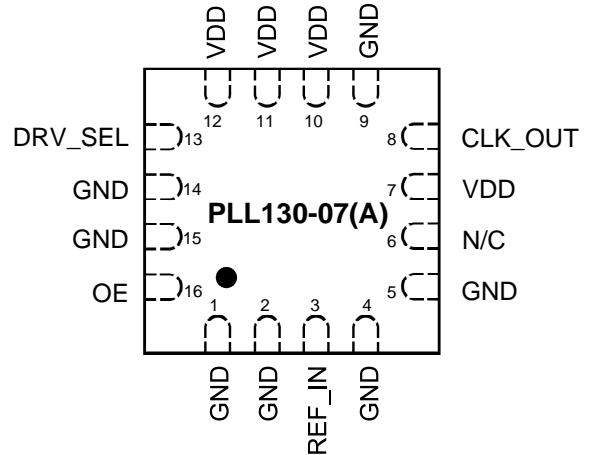
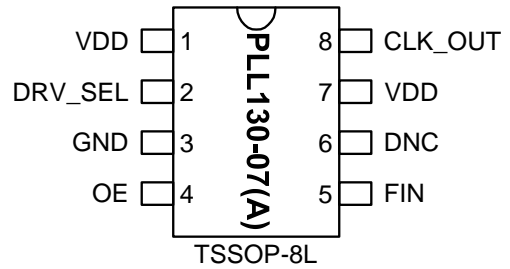
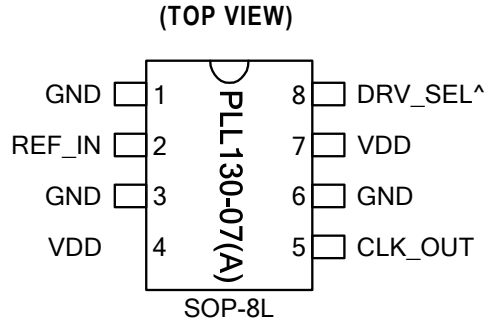

BLOCK DIAGRAM

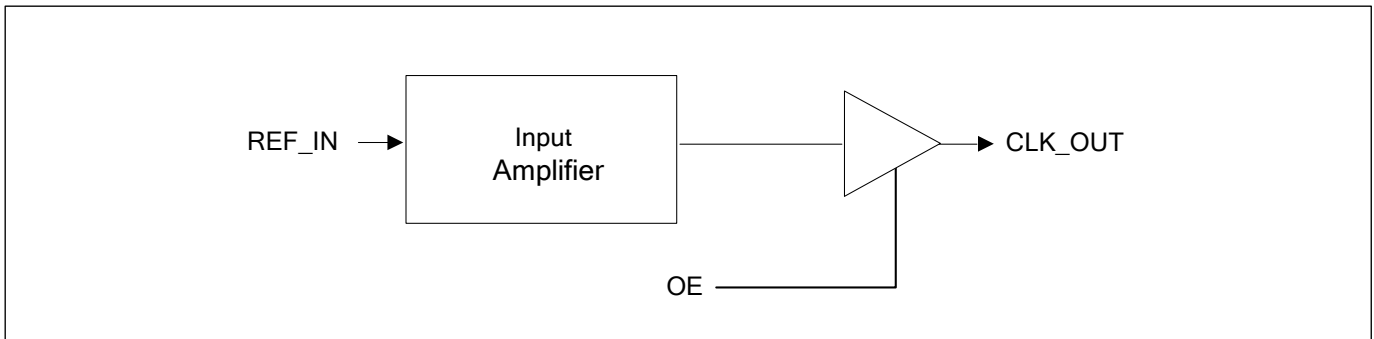

High Speed Translator Buffer to LVCMOS
PIN DESCRIPTION

Name	SOP-8L	TSSOP-8L	QFN-16L	Type	Description
GND	1,3,6	3	1,2,4,5, 9,14,15	P	Ground.
VDD	4,7	1,7	7,10,11,12	P	Power supply.
DRV_SEL	8	2	13	I	Drive Select input: '1' for standard drive, '0' for hi-drive output. Internal pull-up (default is '1').
REF_IN	2	5	3	I	Reference input signal. The frequency of this signal will be reproduced at the output (after translation to CMOS level).
CLK_OUT	5	8	8	O	CMOS clock output.
OE	N/A	4	16	I	Output Enable. See OE LOGIC TABLE below

OE LOGIC TABLE

Part Number	OE State	Output Buffer State
PLL130-07	0	Tri-State
	1 (Default)	Active
PLL130-07A	0 (Default)	Active
	1	Tri-State

ELECTRICAL SPECIFICATIONS
1. Absolute Maximum Ratings

PARAMETERS	SYMBOL	MIN.	MAX.	UNITS
Supply Voltage	V_{DD}		4.6	V
Input Voltage, dc	V_I	-0.5	$V_{DD}+0.5$	V
Output Voltage, dc	V_O	-0.5	$V_{DD}+0.5$	V
Storage Temperature	T_S	-65	150	°C
Ambient Operating Temperature*	T_A	-40	85	°C
Junction Temperature	T_J		125	°C
Lead Temperature (soldering, 10s)			260	°C
ESD Protection, Human Body Model			2	kV

Exposure of the device under conditions beyond the limits specified by Maximum Ratings for extended periods may cause permanent damage to the device and affect product reliability. These conditions represent a stress rating only, and functional operations of the device at these or any other conditions above the operational limits noted in this specification is not implied.

* **Note:** Operating Temperature is guaranteed by design for all parts (COMMERCIAL and INDUSTRIAL), but tested for COMMERCIAL grade only.

High Speed Translator Buffer to LVCMOS
2. AC Specifications

PARAMETERS	CONDITIONS	MIN.	TYP.	MAX.	UNITS
Input Frequency		0		200	MHz
Input Signal Swing	REF_IN input	100			mV
Output Frequency		0		200	MHz

3. CMOS Output Electrical Specifications

PARAMETERS	SYMBOL	CONDITIONS	MIN.	TYP.	MAX.	UNITS
Output High Voltage	V_{OH}	$I_{OH} = -12mA$	2.4			V
Output Low Voltage	V_{OL}	$I_{LO} = 12mA$			0.4	V
Output High Voltage at CMOS level	V_{OHC}	$I_{OH} = -4mA$	$V_{DD} - 0.4$			V
Output Drive Current		At TTL level (High Drive*)	36	51		mA
		At TTL level (Standard Drive)	12	17		mA

* Note: High Drive CMOS is selectable through DRIV_SEL selector input on pin 8(SOP) or 13(QFN).

4. CMOS Switching Characteristics

PARAMETERS	SYMBOL	CONDITIONS	MIN.	TYP.	MAX.	UNITS
Output Clock Rise/Fall Time	t_r / t_f	0.8V ~ 2.0V with 10 pF load		1.15		ns
	t_r / t_f	0.3V ~ 3.0V with 15 pF load		3.7		
Output Clock Rise/Fall Time (High Drive*)	t_r / t_f	0.8V ~ 2.0V with 10 pF load		0.5		
	t_r / t_f	0.3V ~ 3.0V with 15 pF load		1.5		

* Note: High Drive CMOS is selectable through DRIV_SEL selector input on pin 8(SOIC) or 13(QFN).

PACKAGE DRAWINGS (GREEN PACKAGE COMPLIANT)

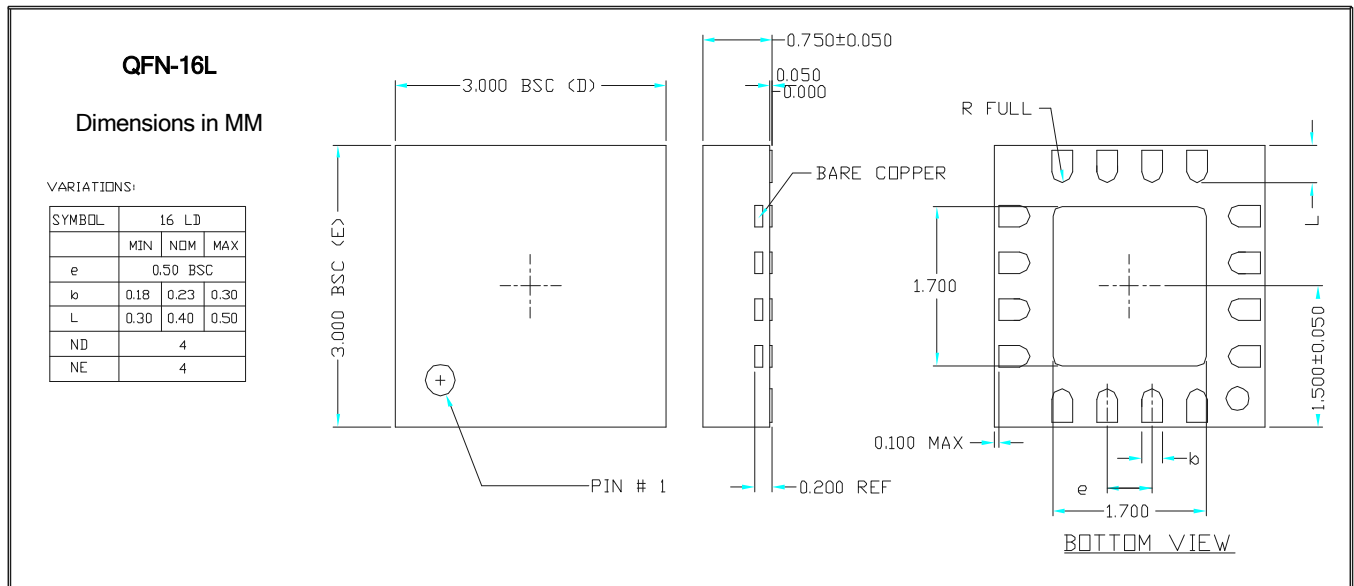
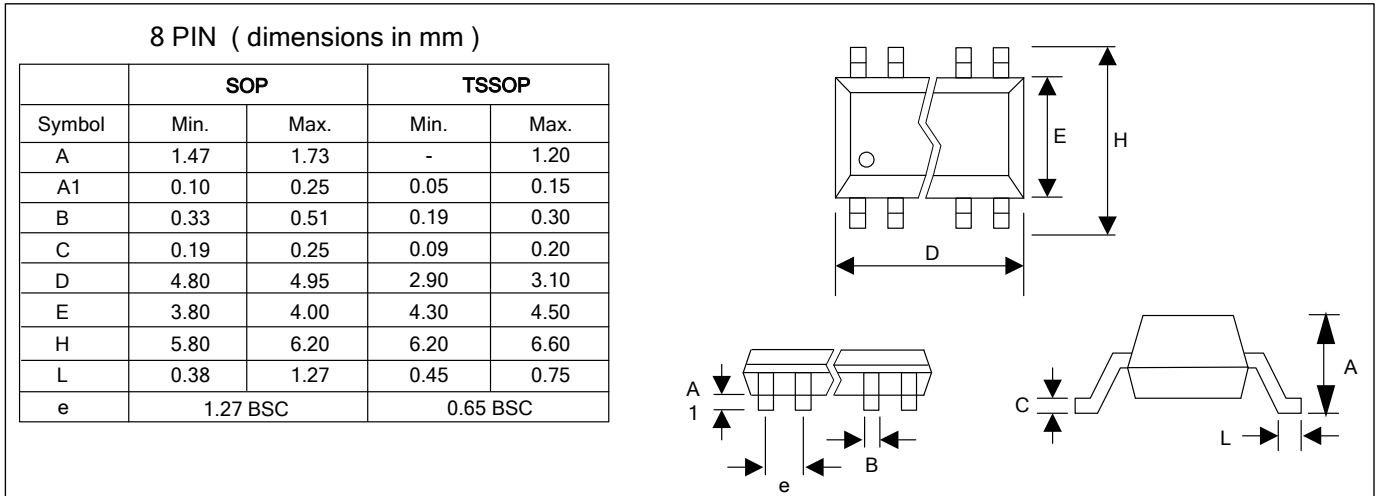

ORDERING INFORMATION (GREEN PACKAGE COMPLIANT)

For part ordering, please contact our Sales Department:

47745 Fremont Blvd., Fremont, CA 94538, USA

Tel: (510) 492-0990 Fax: (510) 492-0991

PART NUMBER

The order number for this device is a combination of the following:
Device number, Package type and Operating temperature range

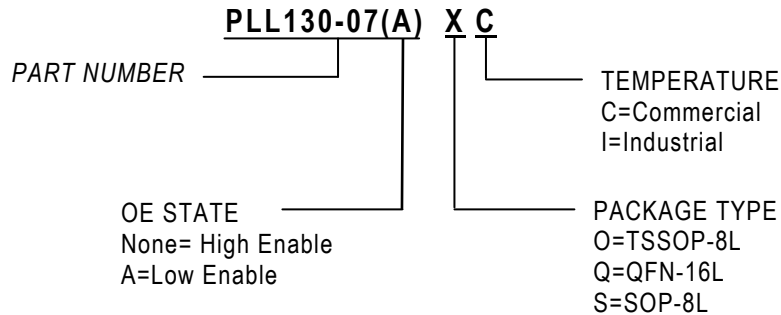

<u>Order Number</u>	<u>Marking</u>	<u>Package Option</u>
PLL130-07OC-R	P130-07OC	TSSOP - Tape and Reel
PLL130-07OC	P130-07OC	TSSOP - Tube
PLL130-07AOC-R	P130-07AOC	TSSOP - Tape and Reel
PLL130-07AOC	P130-07AOC	TSSOP - Tube
PLL130-07QC-R	P130-07QC	QFN - Tape and Reel
PLL130-07AQC-R	P130-07AQC	QFN - Tape and Reel
PLL130-07SC-R	P130-07SC	SOP -Tape and Reel
PLL130-07SC	P130-07SC	SOP - Tube
PLL130-07ASC-R	P130-07ASC	SOP-Tape and Reel
PLL130-07ASC	P130-07ASC	SOP - Tube

PhaseLink Corporation, reserves the right to make changes in its products or specifications, or both at any time without notice. The information furnished by Phaselink is believed to be accurate and reliable. However, PhaseLink makes no guarantee or warranty concerning the accuracy of said information and shall not be responsible for any loss or damage of whatever nature resulting from the use of, or reliance upon this product.

LIFE SUPPORT POLICY: PhaseLink's products are not authorized for use as critical components in life support devices or systems without the express written approval of the President of PhaseLink Corporation.