

**Low Phase Noise VCXO (17MHz to 36MHz)**

**FEATURES**

- VCXO output for the 17MHz to 36MHz range
- Low phase noise (-130dBc @ 10kHz offset at 35.328MHz)
- LVCMOS output with OE tri-state control
- 17 to 36MHz fundamental crystal input
- Integrated high linearity variable capacitors
- 8mA drive capability at TTL output
- ±150 ppm pull range, max 5% (typ.) linearity
- Low jitter (RMS): 2.5ps period jitter
- 2.5 to 3.3V operation
- Available in 8-Pin SOP, 6-pin SOT23 GREEN/ RoHS compliant packages, or Die

**DESCRIPTION**

The PLL500-17 is a low cost, high performance and low phase noise VCXO for the 17 to 36MHz range, providing less than -130dBc at 10kHz offset at 35.328MHz. The very low jitter (2.5 ps RMS period jitter) makes this chip ideal for applications requiring voltage controlled frequency sources. Input crystal can range from 17 to 36MHz (fundamental resonant mode).

**PIN CONFIGURATION**

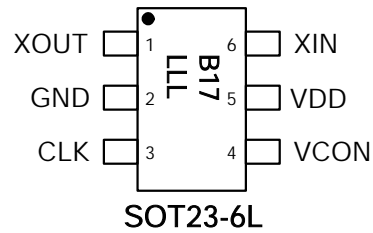
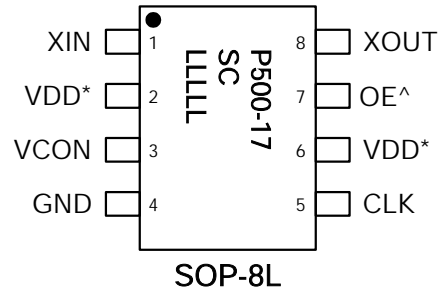

^: Denotes internal Pull-up  
\*: Only one VDD pin needs to be connected

**BLOCK DIAGRAM**

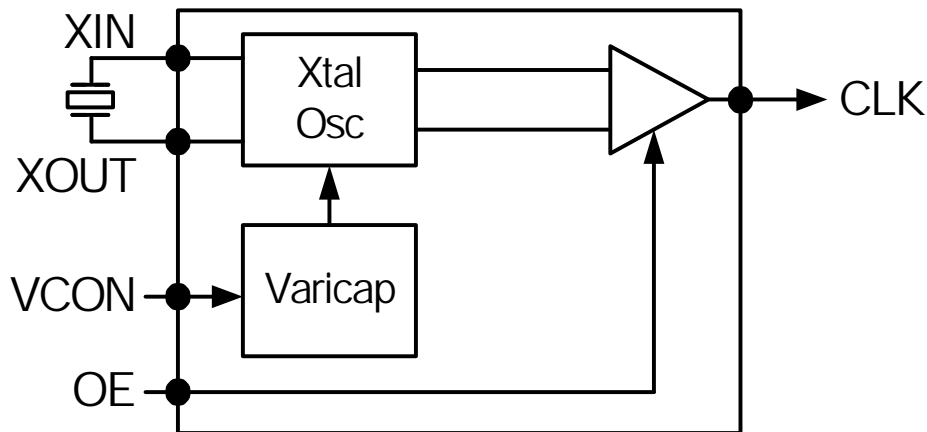

**Low Phase Noise VCXO (17MHz to 36MHz)**

**DIE PAD LAYOUT**

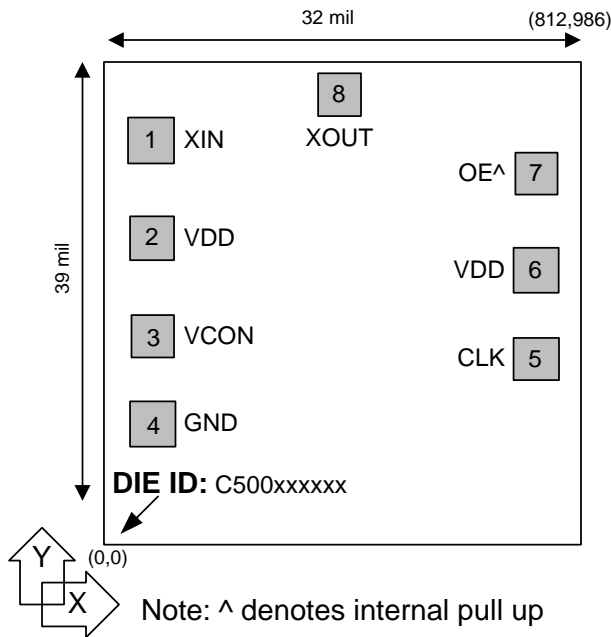

**DIE SPECIFICATIONS**

Name	Value
Size	39 x 32 mil
Reverse side	GND
Pad dimensions	80 micron x 80 micron
Thickness	10 mil

**PACKAGE PIN AND DIE PAD ASSIGNMENT**

Name	Pin#		Die Pad Position		Type	Description
	SOP-8	SOT23-6	X (μm)	Y (μm)		
XIN	1	6	94.183	768.599	I	Crystal input pin.
VDD	2	5	94.157	605.029	P	VDD power supply pin. Only one VDD pin is necessary.
VCON	3	4	94.183	331.756	I	Frequency control voltage input pin.
GND	4	2	94.193	140.379	P	Ground pin.
CLK	5	3	715.472	203.866	O	Output clock pin.
VDD	6	-	715.307	455.726	P	VDD power supply pin. Only one VDD pin is necessary.
OE*	7	-	715.472	626.716	I	Output Enable input pin. Disables the output when low. Internal pull-up enables output by default if pin is not connected to low.
XOUT	8	1	476.906	888.881	I	Crystal output pin. Ref Clock input.

\* OE (Output Enable) pin is not available in SOT23-6L package, the output will always be enabled by the build in pull-up resistor.

**Low Phase Noise VCXO (17MHz to 36MHz)**
**ELECTRICAL SPECIFICATIONS**
**1. Absolute Maximum Ratings**

PARAMETERS	SYMBOL	MIN.	MAX.	UNITS
Supply Voltage	$V_{DD}$		4.6	V
Input Voltage, dc	$V_I$	-0.5	$V_{DD}+0.5$	V
Output Voltage, dc	$V_O$	-0.5	$V_{DD}+0.5$	V
Storage Temperature	$T_S$	-65	150	°C
Ambient Operating Temperature*	$T_A$	-40	85	°C
Junction Temperature	$T_J$		125	°C
Lead Temperature (soldering, 10s)			260	°C
ESD Protection, Machine Model		200		V
ESD Protection, Human Body Model		2		kV

Exposure of the device under conditions beyond the limits specified by Maximum Ratings for extended periods may cause permanent damage to the device and affect product reliability. These conditions represent a stress rating only, and functional operations of the device at these or any other conditions above the operational limits noted in this specification is not implied.\* Note: Operating Temperature is guaranteed by design for all parts (COMMERCIAL and INDUSTRIAL), but tested for COMMERCIAL grade only.

**2. Voltage Control Crystal Oscillator**

PARAMETERS	SYMBOL	CONDITIONS	MIN.	TYP.	MAX.	UNITS
VCXO Stabilization Time *	$T_{VCXOSTB}$	From power valid			10	ms
VCXO Tuning Range		XTAL $C_0/C_1 < 250$ $0V \leq VCON \leq 3.3V$		300		ppm
CLK Output Pullability		$VCON=1.65V, \pm 1.65V$	$\pm 150$			ppm
VCXO Tuning Characteristic				100		ppm/V
Pull Range Linearity					5	%
Power Supply Rejection	PWSRR	Frequency change, $V_{DD} \pm 10\%$	-1		+1	ppm
VCON Pin Input Impedance			2000			$k\Omega$
VCON Modulation BW		$0V \leq VCON \leq 3.3V, -3dB$	18			kHz

Note: Parameters denoted with an asterisk (\*) represent nominal characterization data and are not production tested to any specific limits.

**Low Phase Noise VCXO (17MHz to 36MHz)**
**3. AC Electrical Specifications**

PARAMETERS	SYMBOL	CONDITIONS	MIN.	TYP.	MAX.	UNITS
Input Crystal Frequency	$F_{in}$	Fundamental Mode	17		36	MHz
Output Clock Rise/Fall Time	$t_r / t_f$	0.8V to 2.0V, 10 pF load		1.15		ns
	$t_r / t_f$	0.3V to 3.0V, 15 pF load		3.7		
Output Clock Duty Cycle			45	50	55	%
Output Enable/Disable Time	$t_{OE}$			5		ns
Start-Up Time	$t_{SU}$			1		ms

**4. Jitter and Phase Noise Specifications**

PARAMETERS	CONDITIONS	MIN.	TYP.	MAX.	UNITS
RMS Period Jitter (1 sigma – 1000 samples)	With capacitive decoupling between $V_{DD}$ and GND.		2.5		ps
Phase Noise, Relative to Carrier	27MHz @100Hz offset		-100		dBc/Hz
	27MHz @1kHz offset		-125		dBc/Hz
	27MHz @10kHz offset		-142		dBc/Hz
	27MHz @100kHz offset		-150		dBc/Hz
	27MHz @1MHz offset		-150		dBc/Hz

**5. DC Specifications**

PARAMETERS	SYMBOL	CONDITIONS	MIN.	TYP.	MAX.	UNITS
Supply Current, Dynamic	$I_{DD}$	27MHz, 15pF Load, 3.3V		3.7	5	mA
		27MHz, 15pF Load, 2.5V		2.4	3.5	
Supply Current, Output Disabled	$I_{DD\_OE}$	27MHz, 3.3V, OE=Low		1.4		mA
		27MHz, 2.5V, OE=Low		1		
Operating Voltage	$V_{DD}$		2.25		3.63	V
Output Low Voltage, CMOS	$V_{OLC}$	$I_{OL} = +4mA$			0.4	V
Output High Voltage, CMOS	$V_{OHC}$	$I_{OH} = -4mA$	$V_{DD} - 0.4$			V
Output Drive Current		For $V_{OL} < 0.4V$ or $V_{OH} > 2.4V$	8	9.5		mA
VCXO Control Voltage	VCON		0		$V_{DD}$	V

**Low Phase Noise VCXO (17MHz to 36MHz)**

**6. Crystal Specifications**

PARAMETERS	SYMBOL	MIN.	TYP.	MAX.	UNITS
Crystal Loading Rating (VCON = 1.65V, 3.3V Operation)	$C_{L(xtal)}$ (see note below)		7.8		pF
Crystal Loading Rating (VCON = 1.25V, 2.5V Operation)			8.9		
Maximum Sustainable Drive Level				200	$\mu$ W
Operating Drive Level			50		$\mu$ W
Max C0				5	pF
C0/C1				250	-
ESR	$R_s$			30	$\Omega$

Note: The crystal must be such that it oscillates (parallel resonant) at nominal frequency when presented a C Load as specified above. If the crystal requires more load to be at nominal frequency, the additional load must be added externally. This however may reduce the pull range. Note that the Cload values above are for the IC only, and do not include PCB parasitics. Crystal specifications for Cload include PCB parasitics.

**PACKAGE INFORMATION (GREEN PACKAGE COMPLIANT)**

**SOP-8L**

Symbol	Dimension in MM	
	Min.	Max.
A	1.35	1.75
A1	0.10	0.25
A2	1.25	1.50
B	0.33	0.53
C	0.19	0.27
D	4.80	5.00
E	3.80	4.00
H	5.80	6.20
L	0.40	0.89
e	1.27 BSC	

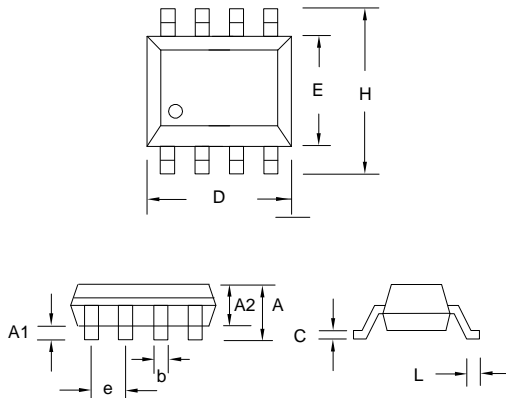

**SOT23-6 L**

Symbol	Dimension in MM	
	Min.	Max.
A	1.05	1.35
A1	0.05	0.15
A2	1.00	1.20
b	0.30	0.50
c	0.08	0.20
D	2.80	3.00
E	1.50	1.70
H	2.60	3.0
L	0.35	0.55
e	0.95 BSC	

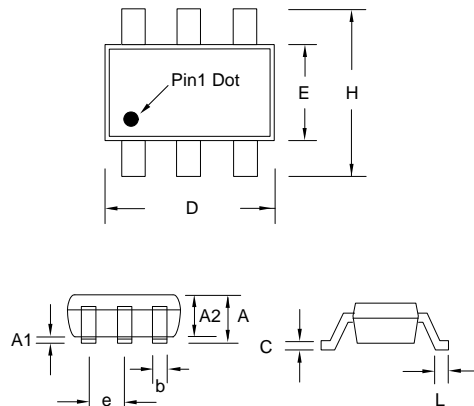

**Low Phase Noise VCXO (17MHz to 36MHz)**

**ORDERING INFORMATION (GREEN PACKAGE)**

For part ordering, please contact our Sales Department:  
47745 Fremont Blvd., Fremont, CA 94538, USA  
Tel: (510) 492-0990 Fax: (510) 492-0991

**PART NUMBER**

The order number for this device is a combination of the following:  
Part number, Package type and Operating temperature range

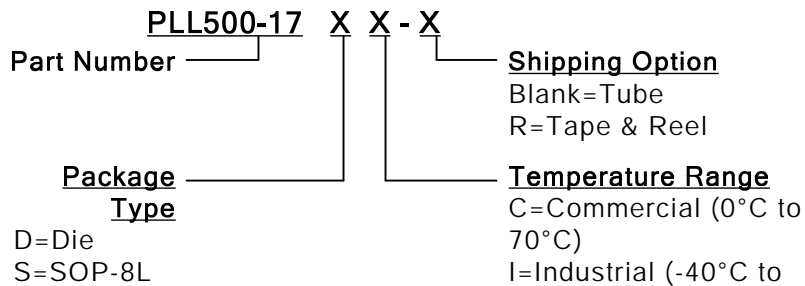

Part / Order Number	Marking*	Package Option
PLL500-17DC		Die (Waffle Pack)
PLL500-17SC	P500-17 SC LLLLL	8-Pin SOP (Tube)
PLL500-17SC-R	P500-17 SC LLLLL	8-Pin SOP (Tape and Reel)
PLL500-17TC-R	B17 LLL	6-Pin SOT23 (Tape and Reel)

\*Note: LLL and LLLLL represent the production lot number

PhaseLink Corporation, reserves the right to make changes in its products or specifications, or both at any time without notice. The information furnished by Phaselink is believed to be accurate and reliable. However, PhaseLink makes no guarantee or warranty concerning the accuracy of said information and shall not be responsible for any loss or damage of whatever nature resulting from the use of, or reliance upon this product.

**LIFE SUPPORT POLICY:** PhaseLink's products are not authorized for use as critical components in life support devices or systems without the express written approval of the President of PhaseLink Corporation.